

## Errata

**Title & Document Type: 8510 Network Analyzer Installation Manual**

**Manual Part Number: 08510-90010**

**Revision Date: September 1985**

---

### HP References in this Manual

This manual may contain references to HP or Hewlett-Packard. Please note that Hewlett-Packard's former test and measurement business is now part of Agilent Technologies. We have made no changes to this manual copy. The HP XXXX referred to in this document is now the Agilent XXXX. For example, model number HP8648A is now model number Agilent 8648A.

### About this Manual

We've added this manual to the Agilent website in an effort to help you support your product. This manual provides the best information we could find. It may be incomplete or contain dated information, and the scan quality may not be ideal. If we find a better copy in the future, we will add it to the Agilent website.

### Support for Your Product

Agilent no longer sells or supports this product. You will find any other available product information on the Agilent Test & Measurement website: [www.tm.agilent.com](http://www.tm.agilent.com).

---

Search for the model number of this product, and the resulting product page will guide you to any available information. Our service centers may be able to perform calibration if no repair parts are needed, but no other support from Agilent is available.

This page has been intentionally left blank.

# HP 8510 NETWORK ANALYZER

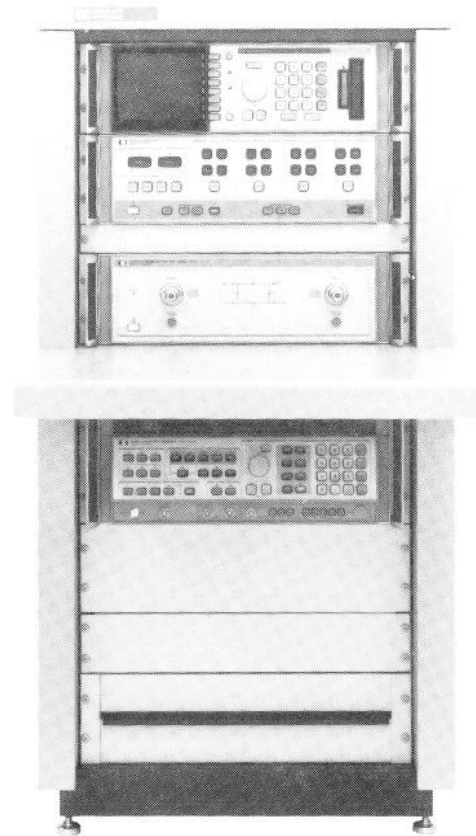

## **CERTIFICATION**

*Hewlett-Packard Company certifies that this product met its published specifications at the time of shipment from the factory. Hewlett-Packard further certifies that its calibration measurements are traceable to the United States National Bureau of Standards, to the extent allowed by the Bureau's calibration facility, and to the calibration facilities of other International Standards Organization members.*

## **WARRANTY**

This Hewlett-Packard instrument product is warranted against defects in material and workmanship for a period of one year from date of shipment. During the warranty period, Hewlett-Packard Company will, at its option, either repair or replace products which prove to be defective.

For warranty service or repair, this product must be returned to a service facility designated by HP. Buyer shall prepay shipping charges to HP and HP shall pay shipping charges to return the product to Buyer. However, Buyer shall pay all shipping charges, duties, and taxes for products returned to HP from another country.

HP warrants that its software and firmware designated by HP for use with an instrument will execute its programming instructions when properly installed on that instrument. HP does not warrant that the operation of the instrument, or software, or firmware will be uninterrupted or error free.

### **LIMITATION OF WARRANTY**

The foregoing warranty shall not apply to defects resulting from improper or inadequate maintenance by Buyer, Buyer-supplied software or interfacing, unauthorized modification or misuse, operation outside of the environmental specifications for the product, or improper site preparation or maintenance.

**NO OTHER WARRANTY IS EXPRESSED OR IMPLIED. HP SPECIFICALLY DISCLAIMS THE IMPLIED WARRANTIES OF MERCHANTABILITY AND FITNESS FOR A PARTICULAR PURPOSE.**

### **EXCLUSIVE REMEDIES**

**THE REMEDIES PROVIDED HEREIN ARE BUYER'S SOLE AND EXCLUSIVE REMEDIES. HP SHALL NOT BE LIABLE FOR ANY DIRECT, INDIRECT, SPECIAL, INCIDENTAL, OR CONSEQUENTIAL DAMAGES, WHETHER BASED ON CONTRACT, TORT, OR ANY OTHER LEGAL THEORY.**

## **ASSISTANCE**

*Product maintenance agreements and other customer assistance agreements are available for Hewlett-Packard products.*

*For any assistance, contact your nearest Hewlett-Packard Sales and Service Office. Addresses are provided at the back of this manual.*

# HP 8510 NETWORK ANALYZER INSTALLATION MANUAL

## SERIAL NUMBERS

This manual applies to HP 8510 network analyzers and test sets with these serial number prefixes:

<b>HP 85101A</b>	2332	2427	<b>HP 8511A</b>	2345
	2438	2452	<b>HP 8512A</b>	2336
			<b>HP 8513A</b>	2345
<b>HP 85102A</b>	2402	2420	<b>HP 8514A</b>	2343
	2446		<b>HP 8515A</b>	2345

©Copyright      HEWLETT-PACKARD COMPANY      1985  
1400 Fountaingrove Parkway, Santa Rosa, CA 95401, U.S.A.

MANUAL PART NUMBER: 08510-90010  
Microfiche Part Number: 08510-90011

Printed: SEPTEMBER 1985





**CONTENTS**

<b>INTRODUCTION</b>	v
<b>OPERATING ENVIRONMENT/PRE-INSTALLATION</b>	2-1
<b>HARDWARE AND FIRMWARE REQUIREMENTS: SYSTEMS USING HP 835x-SERIES SOURCES</b>	2-5
HP 8350B Sweep Oscillators	2-5
HP 83500-series RF Plug-ins	2-6
HP 86200- and 83500-series RF Plug-ins	2-6
HP 8350A Sweep Oscillators	2-6
<b>SYSTEM UNPACKING/SHIPMENT VERIFICATION</b>	2-7
Unpacking	2-7
Detailed Shipment Verification	2-7
<b>INSTRUMENT INSTALLATION: RACK-MOUNTED CONFIGURATIONS</b>	2-10
Instrument Lock Feet Removal	2-10
Rack Mount Flange Installation	2-11
Alternative Configurations using the the HP 85043A Rack	2-12
Rack-Mounted Configurations not using the HP 85043A Rack	2-12
<b>INSTRUMENT INSTALLATION: BENCH CONFIGURATIONS</b>	2-13
Instrument Cooling	2-13
Bench Installation	2-15
<b>LINE VOLTAGE AND FUSE SELECTION</b>	2-17
HP 85101A Display/Processor	2-17
HP 85102A IF Detector, HP 851x Test Sets	2-19
Other Line Voltages	2-20

<b>AC POWER CONNECTIONS AND CABLES</b>	2-21
<b>HP-IB ADDRESSES</b>	2-23
Checking HP-IB Address Settings	2-23
Setting HP-IB Addresses	2-24
<b>ELECTRICAL INTERCONNECTIONS</b>	2-25
Hardline Port Extension Cables	2-26
Electrical Interconnections:	2-27
Systems Using an HP 8340A/41A Synthesized Sweeper	
Electrical Interconnections:	2-34
Systems Using an HP 8350B Sweep Oscillator	
<b>POWER-ON SEQUENCE</b>	2-40
<b>STORAGE AND SHIPMENT</b>	2-41
Shipment	2-41
<b>READER COMMENT SHEET</b>	
<b>SERVICE TAGS</b>	



ILLUSTRATIONS

Figure 2-1.	Unpacking HP 8510 System Instruments	2-8
Figure 2-2.	Uncrating the HP 85043A System Rack	2-9
Figure 2-3.	Lock Feet Removal	2-10
Figure 2-4.	Rack Mount Flange Installation	2-11
Figure 2-5.	Recommended Bench Configurations	2-14
Figure 2-6.	HP 85101A/HP 85102A Rear Lock Feet	2-16
Figure 2-7.	Power Line Module	2-19
Figure 2-8.	Setting the Test Set HP-IB Address	2-24
Figure 2-9.	System Interconnections, HP 8340A/41A Source (1)	2-28
Figure 2-10.	System Interconnections HP 8340A/41A Source (2)	2-30
Figure 2-11.	System Interconnections HP 8340A/41A Source (3)	2-32
Figure 2-12.	System Interconnections, HP 8350B Source (1)	2-34
Figure 2-13.	System Interconnections HP 8350B Source (2)	2-36
Figure 2-14.	System Interconnections HP 8350B Source (3)	2-38

## TABLES

Table	2-1.	Instrument Dimensions	2-1
Table	2-2.	Instrument Weights	2-2
Table	2-3.	Instrument Power Requirements	2-2
Table	2-4.	System Environmental Requirements	2-3
Table	2-5.	Instrument Warmup Times	2-4
Table	2-6.	Other System Information	2-4
Table	2-7.	Modification Kits for HP 83500-Series RF Plug-ins	2-6
Table	2-8.	Line Voltage/Fuse Selection	2-18
Table	2-9.	Mains Plugs and AC Power Cables	2-22
Table	2-10.	Standard HP 8510 System Bus Addresses	2-23
Table	2-11.	Required Cables	2-25

## INTRODUCTION

This HP 8510 network analyzer system Installation Manual explains how to install an HP 8510 system in either a rack-mounted or a bench configuration. The system consists of the HP 8510 network analyzer (HP 85101A and HP 85102A), one of five system test sets (HP 8511A - HP 8515A), and a microwave source (HP 8340A/41A or HP 8350B with RF plug-in). Information on installing controllers and/or peripherals appears in the manuals supplied with those instruments.

In addition to installation, this manual discusses site preparation, unpacking, incoming inspection, operating environment, power requirements, cable interconnections, and packing instruments for re-shipment.

An overview of the whole installation process, from assembling the system manual through performance verification, appears in the HP 8510 Installation Checklist, HP Part Number 08510-90050. A copy is shipped with each system order.

Performance verification after system installation is explained in Section IV (Performance Tests) of the HP 8510 Operating and Service manual.

If option HP 8510T +23N on-site installation and verification has been ordered, contact your Hewlett-Packard Customer Engineer to assist in answering site-preparation questions and, after all of the instruments have arrived, to install the system and conduct its performance verification.

This manual is designed to be useful, and it is based on the experience gained by Hewlett-Packard factory and field personnel actually installing HP 8510 systems. Please let us have your comments, too. A reader comment sheet is enclosed with this manual, postage paid in the United States.



## OPERATING ENVIRONMENT/PRE-INSTALLATION

Tables 2-1 through 2-5 give instrument dimensions, weights, power requirements, environmental characteristics and other operating information useful for preparing an installation site. Environments that contain excessive airborne contaminants, oils, salts, corrosives, extremes in temperature or humidity, vibration, or electromagnetic interference can impair system operation and reduce the useful life of the system. Avoid such areas when choosing an installation site, and consult your Hewlett-Packard Customer Engineer if you have any doubts about the suitability of a given area.

As noted in Table 2-4, ambient temperature of the device under test as compared to the temperature of the calibration device during calibration is critical. The temperature differential between the two devices must be within the calibration window given in Table 2-4 for continued adherence to all HP 8510 accuracy enhanced published specifications. These specifications may be found in Section I (General Information) of the HP 8510 Operating and Service manual. The temperature calibration window is necessarily small. Although certain HP 8510 applications will require a specially conditioned, temperature controlled room, the decision to provide such an environment is discretionary and should be based upon customer need.

*Table 2-1. Instrument Dimensions*

INSTRUMENT	HEIGHT	WIDTH	DEPTH
<b>NETWORK ANALYZER</b>			
HP 85101A	133.4 mm 5.25 inches	460.2 mm 18.125 inches	609.6 mm 24.00 inches
HP 85102A	133.4 mm 5.25 inches	460.2 mm 18.125 inches	612.6 mm 24.125 inches
<b>TEST SETS</b>			
HP 8511A - HP 8515A	133.4 mm 5.25 inches	460.2 mm 18.125 inches	609.6 mm 24.00 inches
<b>SOURCES</b>			
HP 8340A/41A	188.0 mm 7.40 inches	460.2 mm 18.125 inches	609.6 mm 24.00 inches
HP 8350B	133.4 mm 5.25 inches	460.2 mm 18.125 inches	612.6 mm 24.125 inches

Table 2-2. Instrument Weights

INSTRUMENT	NET WEIGHT	SHIPPING WEIGHT
<b>NETWORK ANALYZER</b>		
HP 85101A	14 kg (31 lb)	20 kg (44 lb)
HP 85102A	18 kg (40 lb)	22 kg (48 lb)
<b>TEST SETS</b>		
HP 8511A	13 kg (29 lb)	17 kg (38 lb)
HP 8512A	15 kg (33 lb)	19 kg (41 lb)
HP 8513A	16 kg (35 lb)	20 kg (44 lb)
HP 8514A	17 kg (38 lb)	21 kg (46 lb)
HP 8515A	19 kg (41 lb)	22 kg (48 lb)
<b>SOURCES</b>		
HP 8340A/41A	34 kg (75 lb)	52 kg (112 lb)
HP 8350B	16.5 kg (36 lb)	22.7 kg (50 lb)
HP 8359x-series	6.0 kg (13.2 lb)	9.2 kg (20 lb)
HP 8352x-series HP 8354x-series HP 8357x-series	4.5 kg (10 lb)	7.7 kg (17 lb)

Table 2-3. Instrument Power Requirements

<b>FREQUENCY</b>	
47.5 to 66 Hertz	
<b>VOLTAGE</b>	
100, 120, 200, 240 volts ac, $\pm$ 10%	
<b>POWER CONSUMPTION</b>	
HP 85101A	200 VA maximum
HP 85102A	160 VA maximum
TEST SETS	95 VA maximum
HP 8340A/41A	500 VA maximum (ON) 40 VA maximum (STANDBY)
HP 8350B	270 VA maximum including RF plug-in

Table 2-4. System Environmental Requirements

<b>TEMPERATURE, PRESSURE, HUMIDITY</b>			
<b>GENERAL</b>			
	<b>Operating</b>	<b>Non-Operating/ Storage</b>	<b>HP 98200A Tape Cartridge</b>
<b>Temperature</b>	0 to +55°C (+32 to +131°F)	- 40 to +75°C (- 40 to +167°F)	0 to +45°C (+32 to +113°F)
<b>Humidity</b>	40°C maximum wet-bulb temperature, 5% to 95% RH, non-condensing	65°C maximum wet-bulb temperature, 5% to 95% RH, non-condensing	30°C maximum wet-bulb temperature, 20% to 80% RH, non-condensing
<b>Pressure Altitude</b>	less than 4,600 metres (15,000 feet)	less than 15,300 metres (50,000 feet)	less than 15,300 metres (50,000 feet)
<p><b>ACCURACY-ENHANCED PERFORMANCE</b></p> <p>Measurement calibration must be performed within the window of 20°C to 26°C (68°F to 79°F).</p> <p>Performance verification and actual device measurements must be made within ±1°C (±1.8°F) of the measurement calibration temperature. This is true even if the measurement temperature, found in this way, falls outside the 20°C to 26°C (68°F to 79°F) window for measurement calibration.</p> <p>Examples. If measurement calibration is performed at 23°C (73.4°F), verification and measurements must be made between 22°C (71.6°F) and 24°C (75.2°F). If measurement calibration is performed at 20°C (68°F), verification and measurements must be made between 19°C (66.2°F) and 21°C (69.8°F).</p>			
<p><b>ELECTROMAGNETIC INTERFERENCE</b></p> <p>HP 8510 conducted and radiated interference is in compliance with CISPR Publication 11 (1975), and Messemppfaenger-Postverfuegung 526/527/79 (Kennzeichnung Mit F-Nummer/Funkschutzzeichen).</p>			

Table 2-5. Instrument Warmup Times

<b>NON-ERROR-CORRECTED SPECIFICATIONS VALID</b>	
<b>Instrument</b>	<b>Warmup Time</b>
HP 8510A Test Set HP 8340A/41A HP 8350B	30 minutes
<b>ACCURACY ENHANCEMENT SPECIFICATIONS VALID</b>	
<b>Instrument</b>	<b>Warmup Time</b>
HP 8510A Test Set HP 8340A/41A HP 8350B	1 hour

Table 2-6. Other System Information

<b>MAXIMUM CABLE LENGTHS</b>	
HP 8510 Interface Bus	10 metres (32 feet, 9 inches)
Controller HP-IB Bus	10 metres (32 feet, 9 inches)
HP 8510 Test Set/IF Detector	6 metres (19 feet, 7 inches)
<b>MAXIMUM BIAS RATINGS</b>	
HP 8514A and HP 8515A S-Parameter Test Sets	- 40 V to +40 V at 0.5 A



## HARDWARE AND FIRMWARE REQUIREMENTS: SYSTEMS USING HP 835x-SERIES SOURCES

If an HP 8350B sweep oscillator will be used as the system source, make sure that the necessary hardware and firmware revisions for both the HP 8350 and HP 83500-series RF plug-in have been installed. These are explained in the next several paragraphs. HP 8340A/41A synthesized sweepers equipped with rear panel output Option 004 or 005 can be used as the system source without modification.

### HP 8350B SWEEP OSCILLATORS

When an HP 8350B sweep oscillator is used as the source in an HP 8510 system, the HP 8350B must have system firmware Revision 6. To check the firmware revision number, press the HP 8350 [SHIFT] [4] [9]. The firmware revision number will appear in the right-hand FREQUENCY/TIME display. HP 8350B sweep oscillators shipped after March 30, 1984 are equipped with the correct firmware revision for use in an HP 8510 system. If updating to Revision 6 is required, use the firmware retrofit kit, HP Part Number 08350-60101.

### HP 83500-SERIES RF PLUG-INS

HP 83500-series RF plug-ins (except the HP 83590-series) must have Revision 6 firmware to be compatible with an HP 8510 system. HP 83590-series RF plug-ins require Revision 7 firmware.

To check the plug-in firmware revision number, press the HP 8350 [SHIFT] [9] [9]. The firmware revision number will appear in the plug-in POWER window. HP 83500-series RF plug-ins shipped after March 30, 1984 are equipped with the correct firmware revision for use in an HP 8510 system. If modification is required, the modification kit required for each plug-in model is listed in Table 2-7.

*Table 2-7. Modification Kits for HP 83500-Series RF Plug-ins*

RF PLUG-IN	MODIFICATION KIT
HP 83522A	83525-60074
HP 83525A/B	83525-60074
HP 83540A/B	83525-60074
HP 83545A	83525-60074
HP 83570A	83525-60074
HP 83590A	83590-60074
HP 83592A	83592-60074
HP 83592B	83592-60100
HP 83592C	83592-60102
HP 83594A	83594-60074
HP 83595A	83595-60074

### **HP 86200-SERIES RF PLUG-INS**

HP 86200-series RF plug-ins are incompatible with the HP 8510, and cannot be used.

### **HP 8350A SWEEP OSCILLATORS**

To be used in an HP 8510 system, an HP 8350A sweep oscillator must have an HP 8350A-to-HP 8350B retrofit kit installed. This updates both the firmware and the HP-IB capability. The recommended modification kit is HP Part Number 08350-60100, which replaces the A3, A5, and A8 board assemblies.

## SYSTEM UNPACKING/SHIPMENT VERIFICATION

Regardless of the configuration chosen, all components of the HP 8510 system are shipped to arrive within two weeks of each other. If they do not, contact your Hewlett-Packard Customer Engineer.

Before unpacking any system components, inspect all shipping containers. If any carton or packaging material is damaged, keep it until the entire shipment has been verified for completeness and the instrument has been checked mechanically and electrically.

If the shipment is damaged or incomplete, notify the nearest Hewlett-Packard office. If the shipping container itself is damaged or the packaging material shows signs of stress, also notify the carrier and keep all shipping materials for the carrier's inspection. Hewlett-Packard will arrange for repair or replacement of damaged equipment without waiting for a claim settlement from the carrier.

### UNPACKING

Unpack the HP 8510 system manual set first. The HP 8510 Installation Checklist is packed with the manual set and provides a time-saving overview of the installation process, reference to the particular parts of the manual needed during system installation, and detailed checklists for shipment verification. It is recommended that this Checklist be kept on file for use if the system is ever moved or re-installed.

Figure 2-1 shows how to unpack the two instruments that make up the HP 8510 network analyzer (the HP 85101A display/processor and the HP 85102A IF detector). The same procedure is used to unpack the HP 8510 system test set(s). These instructions are also given with the packing slips on the outside of the instrument boxes.

Figure 2-2 shows how to unpack the HP 85043A system rack. These instructions are also given on the ramp that is part of the shipping crate for the rack.

### DETAILED SHIPMENT VERIFICATION

Verify the completeness of your shipment as it is unpacked by using the packing slips included with each instrument, the checklists provided in the HP 8510 Installation Checklist, and the parts lists in the manuals shipped with such system accessories as calibration and verification kits. It is desirable to keep shipping containers in one area to aid in verifying the receipt of all components ordered.

**INSTRUMENT INSTALLATION: RACK-MOUNTED CONFIGURATIONS**

Instructions for assembling the HP 85043A system rack appear in the system rack manual shipped in the accessories box inside the rack. In addition to the rack itself, Hewlett-Packard offers the HP 92170G work station table and the HP 92209C ergonomic chair as recommended work-station accessories. These should be unpacked and assembled at the same time as the rack.

**INSTRUMENT LOCK FEET REMOVAL**

Before the instruments can be put into the rack, the four plastic lock feet on the bottom panel of each instrument must be removed. Follow the instructions shown in Figure 2-3. If an HP 8350B sweep oscillator is used as the source, remove the instruction card assembly attached to the bottom of the instrument at the same time.

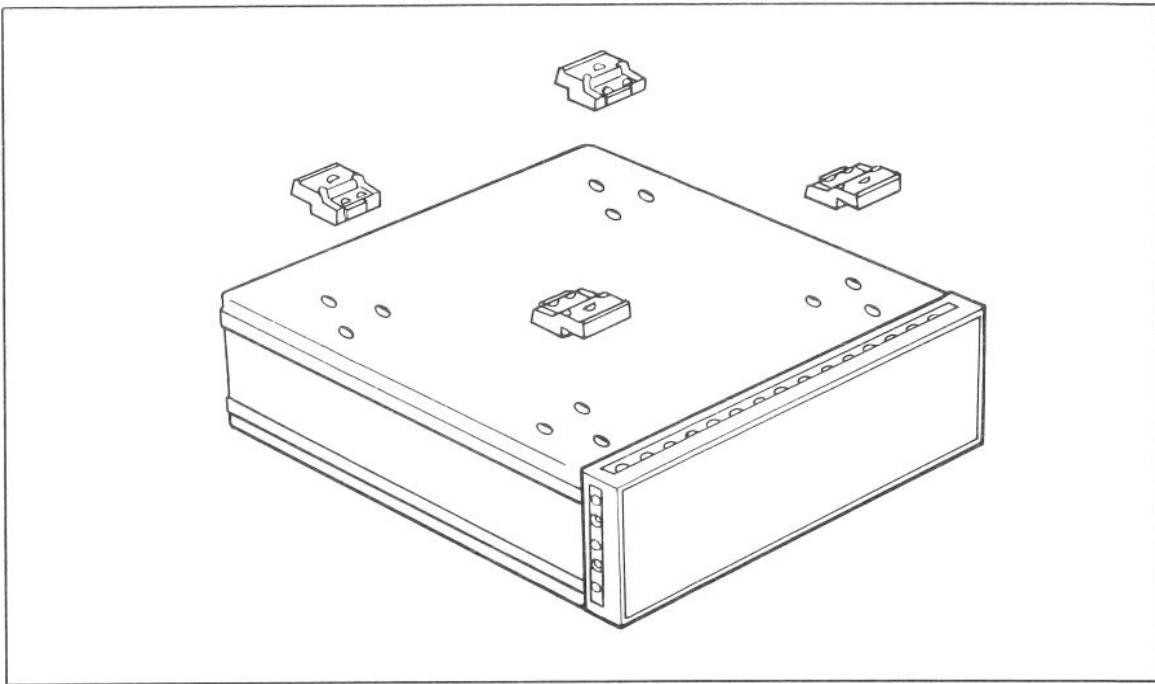

*Figure 2-3. Lock Feet Removal*

## RACK MOUNT FLANGE INSTALLATION

When the lock feet have been removed, install on each instrument the correct rack mount flanges. Follow the instructions shown in Figure 2-4. Hardware and an instruction sheet is packed with each rack mount flange kit. If space is limited, the rack mount flanges can be installed after the instrument has been placed partly into the rack on its support shelves.

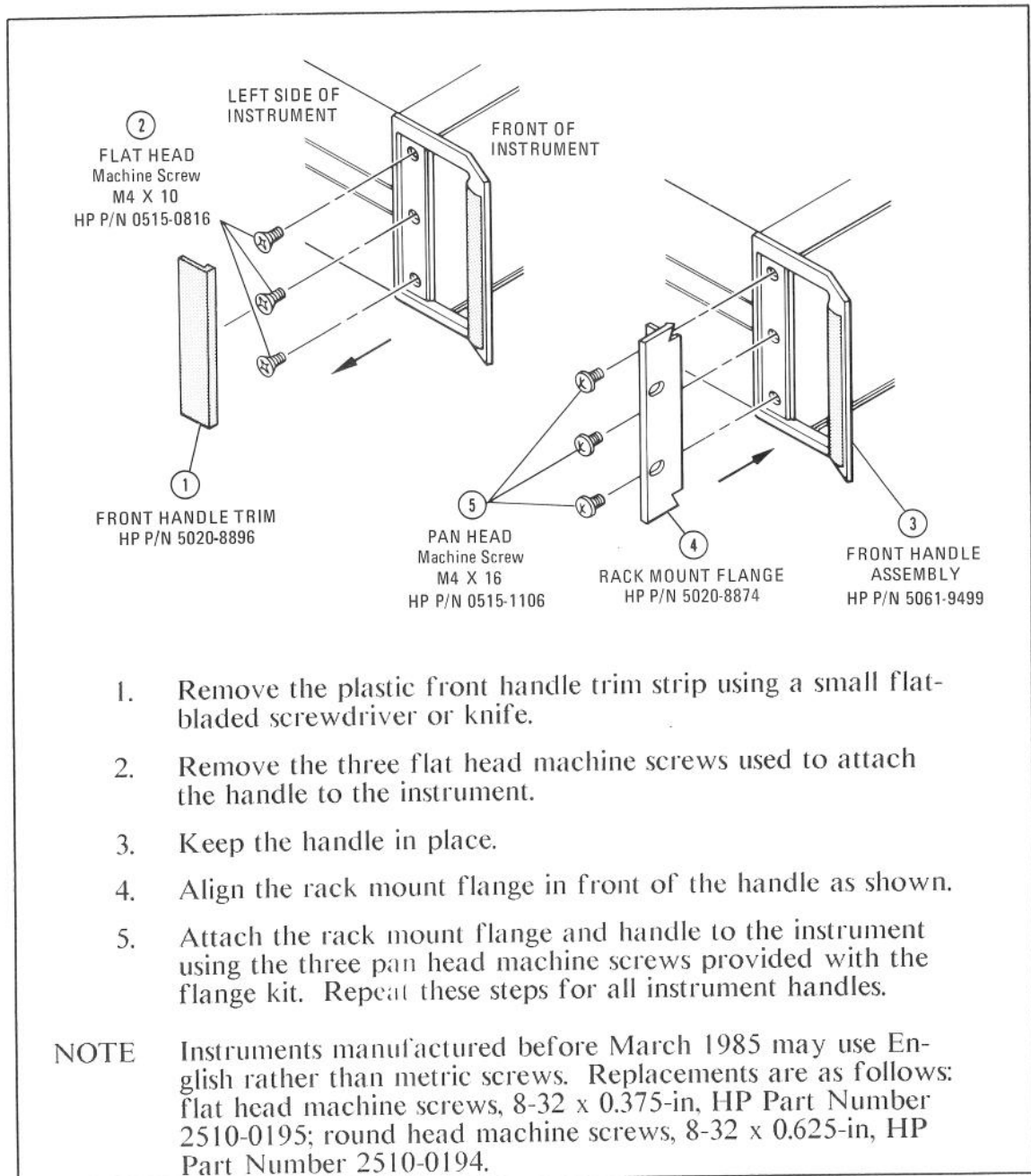

Figure 2-4. Rack Mount Flange Installation

## **ALTERNATIVE CONFIGURATIONS USING THE HP 85043A RACK**

The HP 85043A system rack has been designed specifically for one configuration of the instruments which are used together in the HP 8510 network analyzer system. Other configurations of HP 8510 system instruments in this rack may result in overheating which will adversely affect electrical and mechanical specifications and system reliability.

Using the HP 85043A system rack to hold instruments other than those in the HP 8510 network analyzer system is possible. But this should be done only after careful temperature and air-flow tests have been made of the proposed configuration. These tests are especially necessary because the HP 85043A system rack does not include a cabinet fan.

Consult your Hewlett-Packard Customer Engineer for advice before using a non-standard rack configuration.

## **RACK-MOUNTED CONFIGURATIONS NOT USING THE HP 85043A SYSTEM RACK**

Hewlett-Packard is not obligated to support user-configured rack systems other than the HP 85043A with instruments arranged in the recommended configuration. If a specially-configured rack system is being considered, please consult your Hewlett-Packard Customer Engineer for advice and for warranty and support details. Tables 2-3 through 2-6 in this Installation Manual give information on environmental requirements, power requirements, and maximum cable lengths.

## INSTRUMENT INSTALLATION: BENCH CONFIGURATIONS

Five different bench configurations of HP 8510 network analyzer systems are recommended. These are shown in Figure 2-5. Other bench configurations are not recommended, as they present problems with cooling, cable length limitations, and ease of use. If the system source is the HP 8350B, only configurations C and D can be used. The HP 8350B must not be placed underneath any other instrument.

Configurations A and B are best suited for relatively short benches. Configurations C and D are best suited for relatively tall benches, and one or the other is required if the source is an HP 8350B sweep oscillator. Configuration E is suited for either short or tall benches and uses bench space most efficiently.

In choosing a configuration, pay special attention to the height of the HP 85101A display relative to the user's vision. The center line of the display should be at or slightly above eye level.

### INSTRUMENT COOLING

Take particular note of the horizontal clearances required between instruments shown in the configuration diagrams in Figure 2-5. A minimum clearance of 3 inches (7.6 cm) on both sides is required for instrument cooling.

Several other points about cooling are also essential.

The lock feet on the bottom panel of the HP 85102A IF detector must not be removed in bench configurations. This instrument is cooled by exhausting warm air through the bottom panel. If the lock feet are removed and the bottom cover rests against another flat surface, overheating may result and damage the instrument.

Never place anything on top of a test set that might impede the air flow. Test sets are cooled by exhausting warm air through the top cover as well as through the right rear ventilator panel.

If an HP 8350B sweep oscillator is used as the source, remove the instruction card assembly attached to the bottom of the instrument by removing the lock feet on the bottom panel as shown in Figure 2-3. Then re-install the lock feet.

Do not operate any HP 8510 instrument for extended periods with any cover removed. Adequate cooling is impaired in instruments without all covers on, and overheating and subsequent damage to the instruments could result.

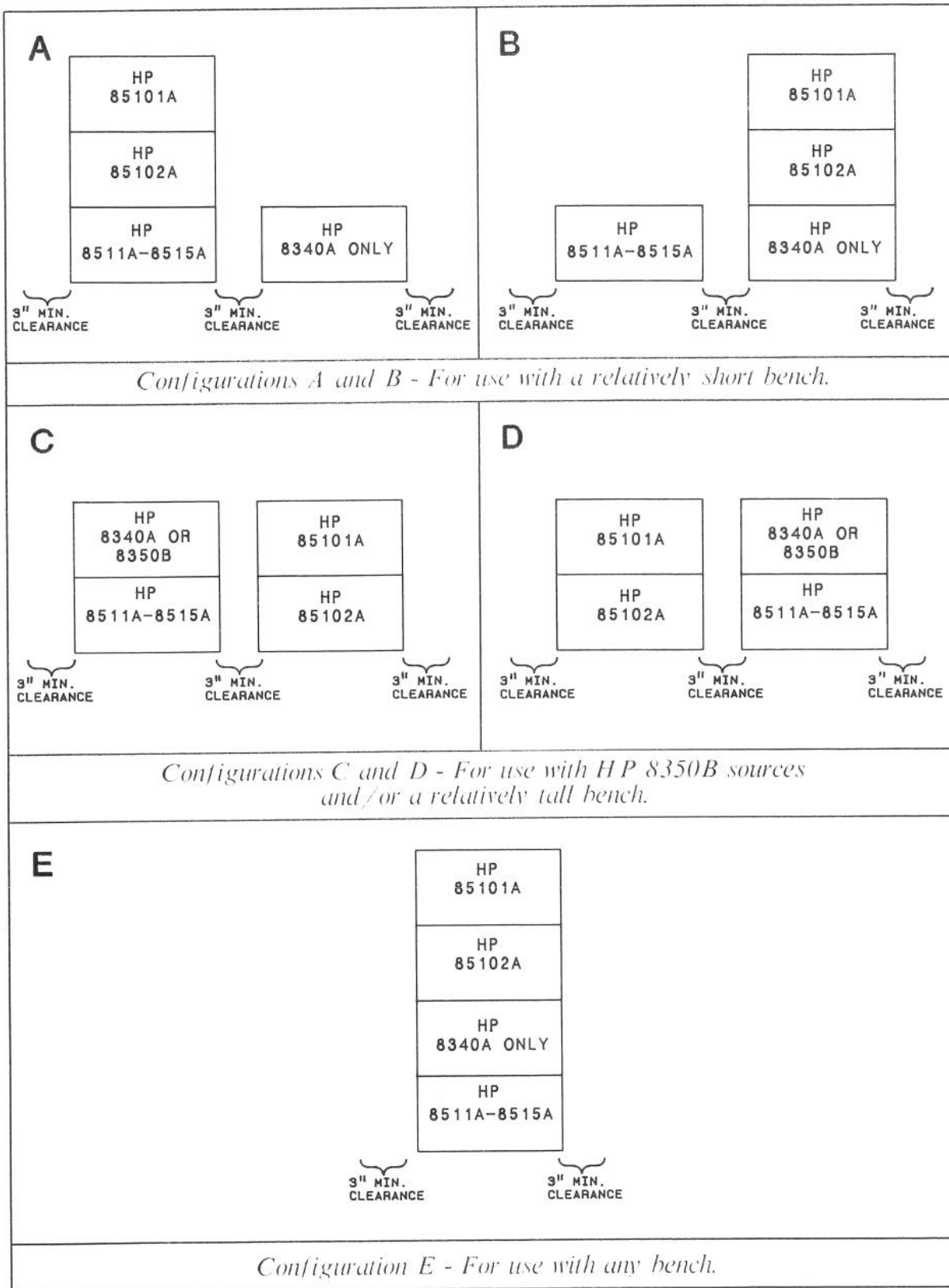

Figure 2-5. Recommended Bench Configurations



## BENCH INSTALLATION

### WARNING

All of the instruments you will be installing are large and heavy. To prevent accidental damage to the instruments or injury to yourself, have someone help you put the instruments in position.

Also be sure to put the HP 85102A IF detector in position *before* putting the HP 85101A display/processor on top of it, and do not attempt to lift these instruments after they have been locked together. Their combined weight is 32 kg (more than 70 lb), and serious personal injury could result.

When a suitable configuration has been chosen from Figure 2-5, place the bottom instrument in each column into its intended final position. Leave at least 3 inches (7.6 cm) clearance on both sides of each instrument for cooling.

If Configuration A or B has been chosen, next place the HP 85102A IF detector on top of the HP 8511A - HP 8515A test set.

If Configuration C, D, or E has been chosen, next place the source (HP 8340A/41A or HP 8350B) on top of the HP 8511A - HP 8515A test set.

Now the HP 85101A display/processor can be put in place and locked to the HP 85102A IF detector. This is done as follows.

First, put the HP 85101A display/processor on top of the HP 85102A IF detector so that the front edge of the HP 85101A is about 0.6 cm (0.25 inch) in front of the HP 85102A.

Second, slide the HP 85101A back until its front edge is even with the front edge of the HP 85102A. Hooks on the top of the HP 85102A will slide into slots on the HP 85101A and lock the fronts of the two instruments together. Check that the two instruments are locked together by lifting up on the front of the HP 85101A.

Finally, at the rear of the two instruments, tighten the thumbscrews on the rear lock feet on the bottom of the HP 85101A into the rear lock feet on the top of the HP 85102A as shown in Figure 2-6.

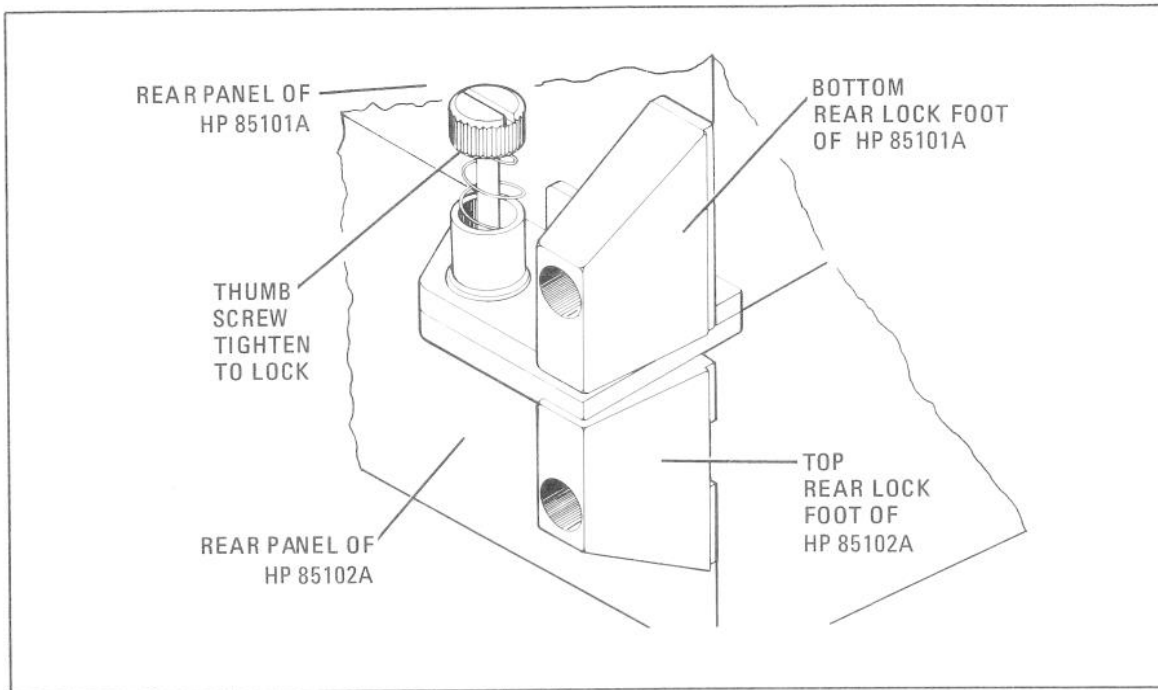

*Figure 2-6. HP 85101A/HP 85102A Rear Lock Feet*

## LINE VOLTAGE AND FUSE SELECTION

### CAUTION

**Line voltage and fuse selections must be made before power is applied to any instrument. This is true of both rack-mounted and bench installations.**

**Failure to set these instrument ac power inputs correctly could cause severe damage to the instruments when power is turned on.**

In both rack-mounted and bench installations, the line voltage and fuses for each instrument must be set according to the voltage of the ac power source. Details appear in Table 2-8.

Line voltage is set for the HP 85101A display/processor by means of a line voltage selector switch on the rear panel of the instrument. For the HP 85102A IF detector and the HP 8511A - HP 8515A test sets, line voltage is set by aligning the voltage selector cards in the rear panel power line module. To set the line voltage for the sources and any peripherals used in the HP 8510 system, consult the Operating and Service manuals supplied with those instruments.

### HP 85101A DISPLAY/PROCESSOR

Set the line voltage and select the correct fuse for the HP 85101A display/processor as follows:

Remove the HP 85101A fuse from the fuse holder located on the rear panel of the HP 85101A display/processor, in the upper right-hand corner above the power cord receptacle. A medium-sized flat-bladed screwdriver is required.

Consult Table 2-8 to determine which fuse is correct for the ac line voltage that will be used. (This information also appears on the rear panel, above the fuse.) If the fuse is not correct, replace it with the correct fuse.

Set the line voltage selector switch located on the rear panel of the HP 85101A display/processor, below the serial number tag. The 115V position is correct for ac line voltages from 90 V to 143 V. The 230V position is correct for ac line voltages from 196 V to 246 V.

Table 2-8. Line Voltage/Fuse Selection

<b>INSTRUMENT</b>	<b>ACTUAL LINE VOLTAGE (VOLTS AC)</b>	<b>VOLTAGE SELECTOR SWITCH POSITION</b>	<b>FUSE HP Part Number</b>
<b>HP 85101A</b>	90 V to 143 V	115 V	2.5 A 2110-0083 (fast blow)
	196 V to 264 V	230 V	1.5 A 2110-0043 (fast blow)
<b>INSTRUMENT</b>	<b>ACTUAL LINE VOLTAGE (VOLTS AC)</b>	<b>PC SELECTOR BOARD POSITION</b>	<b>FUSE HP Part Number</b>
<b>HP 85102A</b>	90 V to 110 V	100	2.0 A 2110-0002 (fast blow)
	108 V to 132 V	115/120	
	198 V to 242 V	220	1.0 A 2110-0001 (fast blow)
	216 V to 264 V	230/240	
<b>TEST SETS</b>  HP 8511A HP 8512A HP 8513A HP 8514A HP 8515A	90 V to 110 V	100	1.5 A 2110-0043 (fast blow)
	108 V to 132 V	115/120	
	198 V to 242 V	220	0.75 A 2110-0063 (fast blow)
	216 V to 264 V	230/240	
<b>SOURCES and PERIPHERALS</b>	Refer to individual Operating and Service manuals.		

**HP 85102A IF DETECTOR, HP 851x TEST SETS**

Follow the steps given in Figure 2-7 to set the line voltage and select the correct fuse for the HP 85102A IF detector and for all HP 8511A - HP 8515A test sets. The power line modules for these instruments are located in the lower left-hand corner of the rear panel, adjacent to the power cord receptacle.

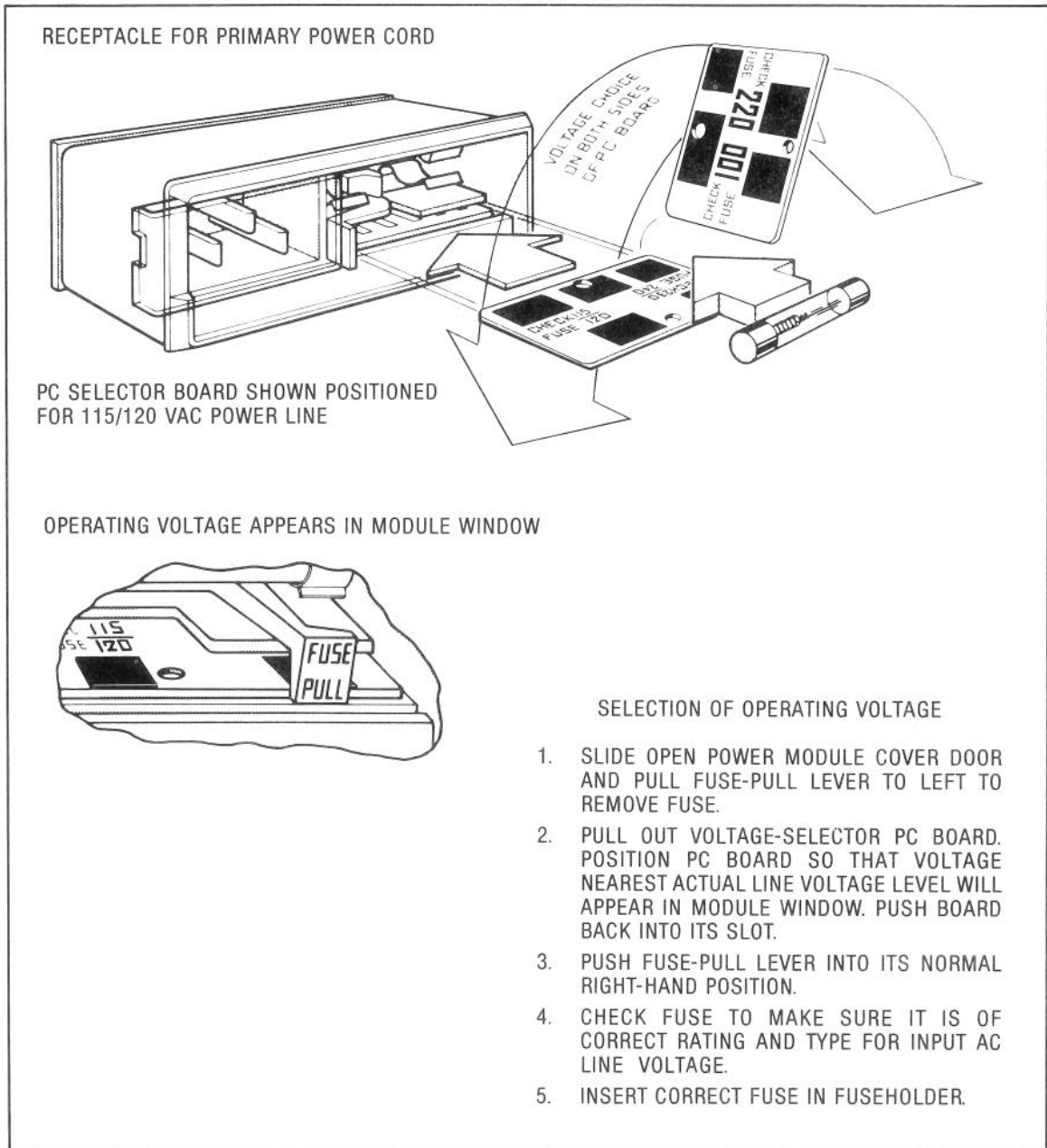

Figure 2-7. Power Line Module

## OTHER LINE VOLTAGES

The line voltages marked on the HP 85101A voltage selector switch (115 V, 230 V) and PC selector boards (100, 115/120, 220, 230/240) are nominal voltages. But each of these nominal settings will accept a range of actual voltages, given in Table 2-8. If the actual voltage is within the necessary range, it is not necessary for nominal voltage marked on the switch or PC selector board to match it exactly.

If, however, the actual voltage used is not within any of the ranges shown in Table 2-8, an autotransformer is required between the source of ac power and all HP 8510 system instruments. Consult your Hewlett-Packard Customer Engineer for help in making such an installation.

### WARNING

The common terminal of any autotransformer used with an HP 8510 system instrument must be connected to earth ground. The protective earth terminals of the HP 8510 system instruments must also be connected to earth ground.

This protection must not be negated through the use of an extension cord (power cable) without a protective ground conductor. Any interruption of the protective ground, inside or outside the instruments, can result in personal injury, or even death.

## AC POWER CONNECTIONS AND CABLES

In compliance with international safety standards, the HP 8510 system instruments are equipped with three-wire power cables. When connected to properly installed power line outlets, these cables ground the individual chassis of these instruments. Table 2-9 shows the different kinds of mains plugs available for the power cables supplied with HP 8510 instruments. The number shown under each plug is the HP part number for the HP 8510 power cable with that kind of mains plug.

The power cable supplied with HP 8510 instruments is selected to be compatible with power line outlet sockets in the country of destination. If the cable you receive does not fit your power line outlet socket, refer to Table 2-9 to determine which cable is correct. Order the required cable by the HP part number shown from the nearest Hewlett-Packard office.

Power cable connections to the HP 85043A system rack are discussed in the system rack manual.







### WARNING

**Before applying ac power to any instruments or to the system rack, be sure that the ac power inputs of all instruments are set to the correct ac line voltage and that correct fuses have been installed.**

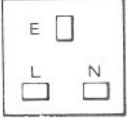
**Also make sure that the ac power outlet to be used is properly grounded and able to supply the maximum power required for the installation.**

**Failure to observe these precautions could result in serious personal injury or major damage to the instruments or both.**

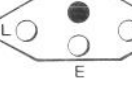
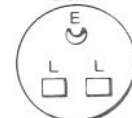
Table 2-9. Mains Plugs and AC Power Cords

Plug Type <sup>1</sup>	Cable HP Part Number <sup>2</sup>	CD <sup>3</sup>	Plug Description <sup>2</sup>	Cable Length (inches)	Cable Color	For Use in Country
<b>250V</b> 	8120-1351 8120-1703	0 6	Straight BS1363A 90°	90 90	Mint Gray Mint Gray	United Kingdom, Cyprus, Nigeria, Zimbabwe, Singapore
<b>250V</b> 	8120-1369 8120-0696	0 4	Straight NZSS198/ASC112 90°	79 87	Gray Gray	Australia, New Zealand
<b>250V</b> 	8120-1689 8120-1692	7 2	Straight CEE7-VII 90°	79 79	Mint Gray Mint Gray	East and West Europe, Saudi Arabia, Egypt, Republic of So. Africa, India (unpolarized in many nations)
<b>125V</b> 	8120-1348 8120-1398 8120-1754 8120-1378 8120-1521 8120-1676	5 5 7 1 6 2	Straight NEMA5-15P 90° Straight NEMA5-15P Straight NEMA5-15P 90° Straight NEMA5-15P	80 80 36 80 80 36	Black Black Black Jade Gray Jade Gray Jade Gray	United States, Canada, Japan (100V or 200V), Mexico, Philippines, Taiwan
<b>250V</b> 	8120-2104	3	Straight SEV1011.1959 24507, Type 12	79	Gray	Switzerland
<b>250V</b> 	8120-0698	6	Straight NEMA6-15P			United States, Canada
<b>220V</b> 	8120-1957 8120-2956	2 3	Straight DHCK 107 90°	79 79	Gray Gray	Denmark
<b>250V</b> 	8120-1860	6	Straight CEE22-VI (System Cabinet Use)			

1. E = Earth Ground; L = Line; N = Neutral  
 2. Part number shown for plug is industry identifier for plug only. Number shown for cable is HP Part Number for complete cable including plug.  
 3. The Check Digit (CD) is a coded digit that represents the specific combination of numbers used in the HP Part Number. It should be supplied with the HP Part Number when ordering any of the power assemblies listed above, to expedite speedy delivery.



**HP-IB ADDRESSES**

Before interconnecting the HP 8510 system, verify that the HP-IB address setting for each instrument (and peripheral, if used) is as given in Table 2-10. The HP 8510 system bus expects the HP-IB addresses of the source, test set, printer, and plotter to be as given in Table 2-10. These are the standard addresses.

*Table 2-10. Standard HP 8510 System Bus Addresses*

Source Address	19
Test Set Address	20
Printer Address	01
Plotter Address	05
8510 HP-IB Address	16
System Bus Address	17
Pass Thru Address	31

**CHECKING HP-IB ADDRESS SETTINGS**

When the HP 8510 system is running, it is possible to check the address of any instrument, the 8510 HP-IB address, the system bus address, or the pass thru address by pressing the front-panel key labeled **LOCAL** or the **SYSTEM MENU** key. Then press the softkey labeled **HP-IB ADDRESSES** to bring the Address Menu onto the CRT. Then press the softkey corresponding to the instrument or bus desired. Its address will appear in the active function area of the CRT.

To change this address, enter the new address desired using the **ENTRY** block keys, following it by **x1**. For the source, test set, plotter, or printer the address becomes effective the next time the HP 8510 addresses the instrument.

## SETTING HP-IB ADDRESSES

Consult the individual Operating and Service manuals for information on checking and setting the HP-IB addresses of the source, printer, and plotter that will be used.

Figure 2-8 shows how to check and set the address of HP 8511A - HP 8515A test sets. In the example shown, the test set address is set correctly to 20. The address is read in binary, with the most significant digit on the right. Thus the address shown, in binary, is 10100, which corresponds to a decimal address of 20. To change the address, set the five switches either on (1) or off (0) to produce the desired address in binary.

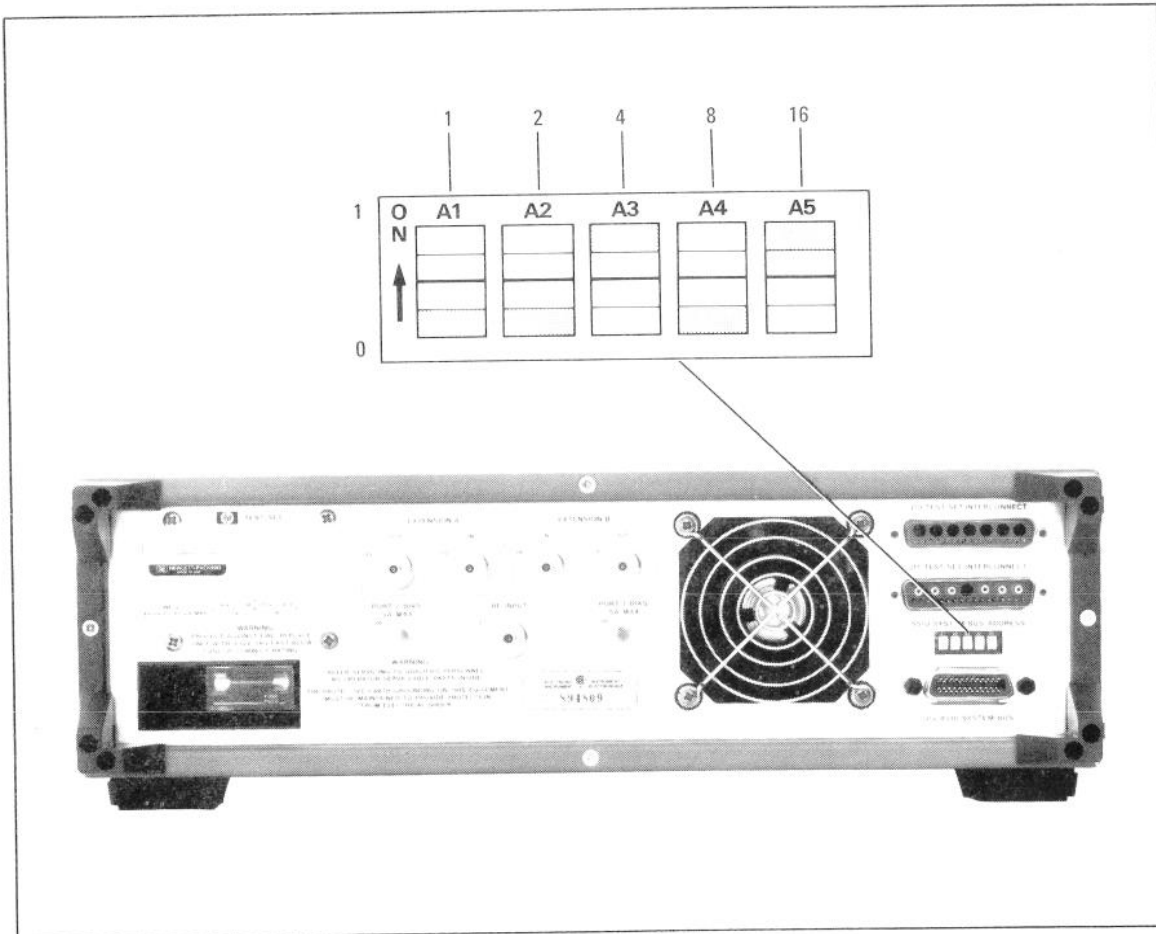

Figure 2-8. Setting the Test Set HP-IB Address

## ELECTRICAL INTERCONNECTIONS

The cables listed in Table 2-11 are required for electrical interconnection of the instruments in the HP 8510 system. They are shipped in the accessories box for the HP 85101A display/processor and in the accessories box shipped with each test set.

In bench installations, the ac power cord listed, HP Part Number 8120-1348, is standard for the United States and Canada. Two such cords are supplied in the HP 8510 accessories box and one in each test set accessories box. Different ac power cords may be required in other locations and are listed in Table 2-9.

In rack-mounted installations, instrument ac power connections are made inside the HP 85043A system rack cabinet. The instruments are connected directly to the power strip inside the cabinet, using the 3-conductor grounded power cords supplied with the system rack. These power cords can and should be used without modification--for all ac line voltages and no matter what type of 3-conductor grounded power plug is used for the external ac power connection. Use these cables instead of the power cords supplied with the instruments.

The Type N (male)-to-SMA (male) adapter, HP Part Number 1250-1894, is shipped with each test set but is needed only if the source used is the HP 8341A synthesized sweeper or the HP 8350B sweep oscillator.

Table 2-11. Required Cables

DESCRIPTION	QUANTITY	HP PART NUMBER
AC Power Cord	3	8120-1348
BNC Cables, 0.9 metre (3 feet)	2	8120-2582
HP-IB Cables, 1 metre (3.3 feet) Model 10833A	2	8120-3445
IF/Display Interconnect Cable Assembly	1	08510-60101
Test Set/IF Display Interconnect Cable Assembly	1	08510-60102
Hardline Port Extension Cables (short)	2	08512-20019
Hardline Port Extension Cables (long)	2	08512-20013
Type N (Male)-to- SMA (Male) Adapter	1	1250-1894
Flexible Source Cable	1	08513-60009

## **HARDLINE PORT EXTENSION CABLES**

Hardline port extension cables are used to balance the reference and test signal path lengths. They are connected on the test set rear panel, at J2 and J3 for Extension A, at J4 and J5 for Extension B.

A 3.5mm torque wrench (5/16-inch, open end) set to 8 in-lb is required. This wrench is available as HP Part Number 1250-1863 and is included in the HP 85052A 3.5mm calibration kit unless deleted by calibration kit Option 020.

Which hardline cable to use (short or long) depends on the test set and on the test port return cables that will be used in actual measurements. These requirements are discussed in the next three paragraphs.

**Reflection/Transmission Test Sets: HP 8512A, HP 8513A.** The standard test setup for these test sets uses either an HP 85132A or an HP 85131A cable and a 20 dB or 10 dB attenuator. The device-under-test is connected directly to Port 1 of the test set. In this situation, use the short hardline port extension cables, HP Part Number 08512-20019.

**S-Parameter Test Sets: HP 8514A, HP 8515A.** The standard test setup for these test sets uses either the HP 85132B or the HP 85131B cable set. The device-under-test is connected between the two cables. In this situation, use the long hardline port extension cables, HP Part Number 08512-20013.

If the device-under-test is connected directly to Port 1 of an S-parameter test set and a single cable (HP 85132A or HP 85131A) is used, use the short hardline port extension cables, HP Part Number 08512-20019.

**ELECTRICAL INTERCONNECTIONS:  
SYSTEMS USING AN HP 8340A/41A SYNTHESIZED SWEEPER**

Figures 2-9 through 2-11 show the electrical interconnections to be made if the source used in the system is an HP 8340A/41A synthesized sweeper. Instructions for making instrument interconnections if the source is an HP 8350B sweep oscillator are given in the next section of this manual.

The instruments in Figures 2-9 through 2-11 are arranged in Configuration B using the HP 8340A/41A synthesized sweeper as the source (Figure 2-5). The same connections should be made in the same order if another HP 8340A/41A bench configuration is used and in all rack-mounted HP 8340A/41A installations.

<b>INTERCONNECTION SEQUENCE (HP 8340A/41A SOURCE)</b>	
1.	<p>Connect  <b>HP 8340A/41A power line module</b> to <b>ac power source</b>                      (lower left, rear panel)</p> <p><b>Cable</b> - AC Power Cord, HP 8120-1348 (USA and Canada).                      Rack-mounted installations use special cord.                      See Table 2-9 for other applications.</p> <p>Set HP 8340A/41A switch to <b>STANDBY</b></p>
2.	<p>Connect  <b>HP 8340A/41A: STOP SWP IN/OUT</b> to <b>HP 85102A: SOURCE STOP SWEEP</b>                      (above 8410B/C interface connection) (below and right of fan)</p> <p><b>Cable</b> - BNC, HP 8120-2582</p>
3.	<p>Connect  <b>HP 8340A/41A: SWEEP OUTPUT</b> to <b>HP 85102A: SOURCE SWEEP IN 0-10V</b>                      (above power line module) (right of fan)</p> <p><b>Cable</b> - BNC, HP 8120-2582</p>
4.	<p>Connect  <b>Test Set: J12 8510 SYSTEM BUS connector</b> to <b>HP 85101A: 8510 INTERCONNECT</b>                      (below 8510 SYSTEM BUS ADDRESS switch) (near and left of fan)</p> <p><b>Cable</b> - HP-IB, HP 8120-3445 (Model 10833A)</p>
5.	<p>Connect  <b>HP 8340A/41A: HP-IB connector</b> to <b>Test Set: J12 8510 SYSTEM BUS connector</b>                      (right of fan) (below SYSTEM BUS ADDRESS switch)</p> <p><b>Cable</b> - HP-IB, HP 8120-3445 (Model 10833A)</p>
	<i>continued</i> →

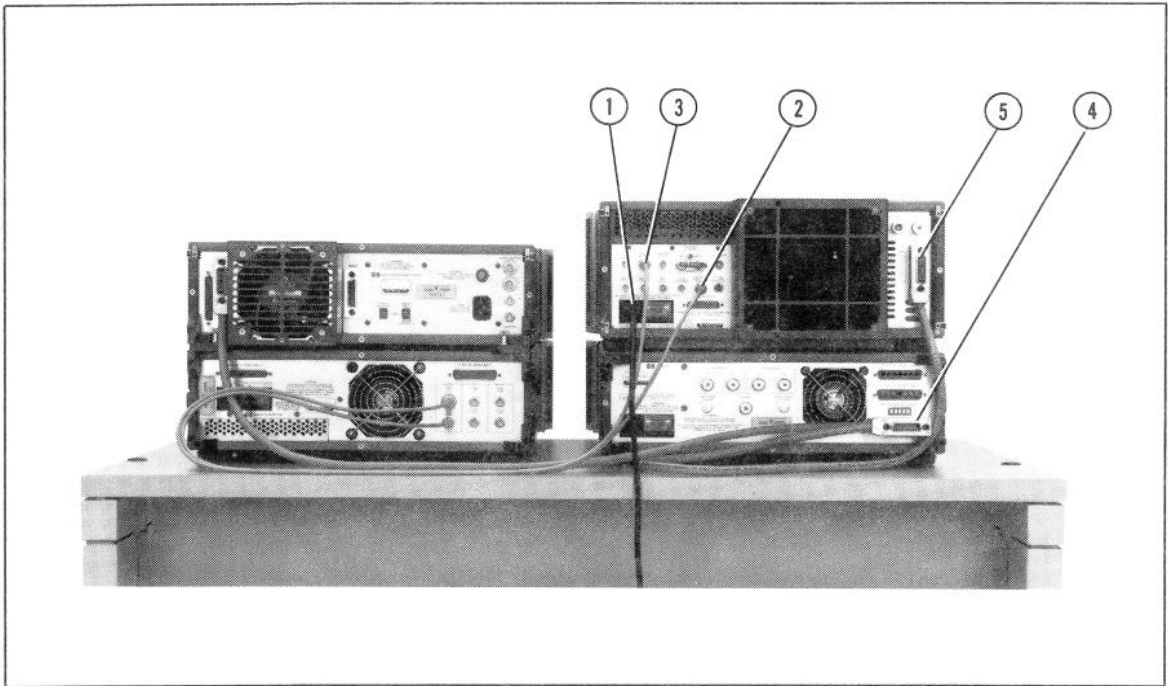

*Figure 2-9. System Interconnections, HP 8340A/41A Source (1)*

INTERCONNECTION SEQUENCE (HP 8340A/41A SOURCE) - 2	
6.	<p>Connect  <b>HP 85102A: J2 IF-DISPLAY INTERCONNECT</b> to <b>HP 85101A IF-DISPLAY INTERCONNECT</b>                      (above power line module) (away and left of fan)  <b>Cable - IF-Display Interconnect Cable, HP 08510-60101</b></p>
7.	<p>Connect  <b>Plotter or Printer (if used)</b> to <b>HP 85101A: 8510 SYSTEM BUS connector</b>                      (near and left of fan)  <b>Cable - HP-IB. Route cable through brush seal on side of rack cabinet in rack-mounted installations.</b></p>
8.	<p>Connect  <b>HP 85102A: J1 TEST SET INTERCONNECT</b> to <b>Test Set: J11 TEST SET INTERCONNECT</b>                      (right of fan) (above SYSTEM BUS ADDRESS switch)  <b>Cable - Test Set-IF Interconnect Cable, HP 08510-60102</b></p>
9.	<p>Connect  <b>Controller: HP-IB (if used)</b> to <b>HP 85101A: HP-IB Connector</b>                      (right of fan)  <b>Cable - HP-IB. Route cable through brush seal on side of rack cabinet in rack-mounted installations.</b></p>
	<i>continued →</i>



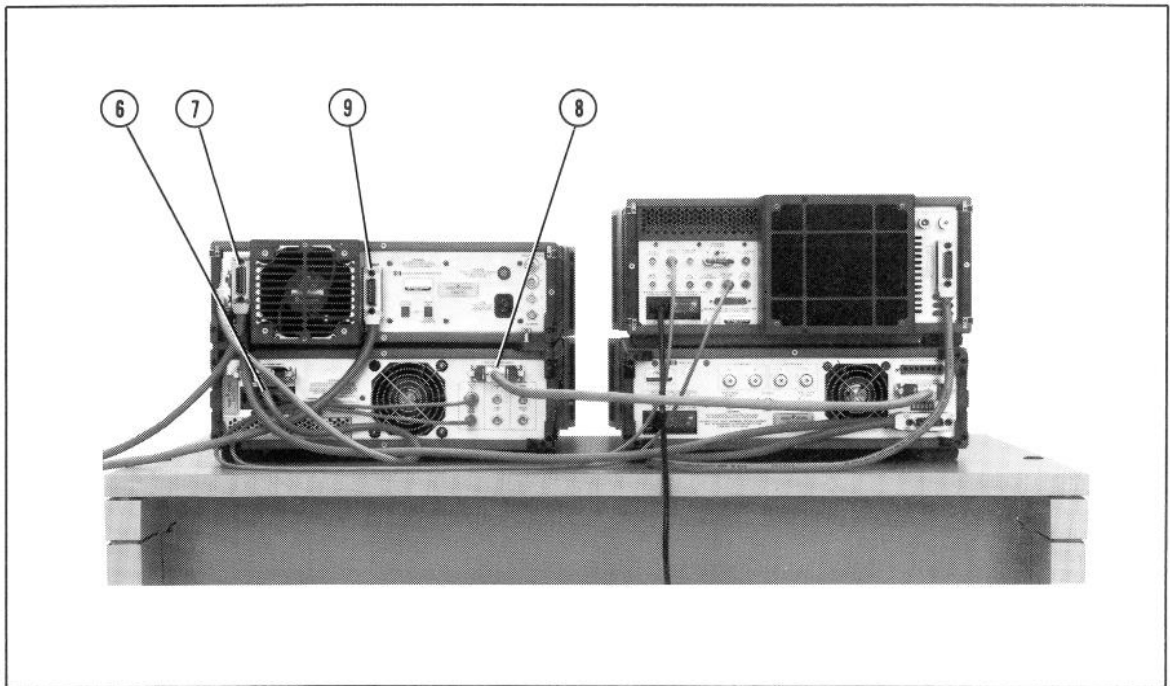

*Figure 2-10. System Interconnections, HP 8340A/41A Source (2)*

<b>INTERCONNECTION SEQUENCE (HP 8340A/41A SOURCE) - 3</b>	
10.	<p>Connect  <b>Test Set: Extension A, Extension B</b>                      (J2 to J3 <i>and</i> J4 to J5: connect both cables)</p> <p><b>Cables</b> - Hardline Port Extension Cables,                      HP 08512-20019 (short) <i>or</i> HP 08514-20013 (long).                      See page 2-26.</p> <p><b>Wrench</b> - 3.5mm torque wrench, 5/16-inch open-end,                      set to 8 in-lb, HP 1250-1863</p>
11.	<p>Connect  <b>HP 8340A/41A: RF OUTPUT</b> to <b>Test Set: RF INPUT</b>                      (above HP-IB connector) (below reference port extension                      cable connections)</p> <p><b>Cable</b> - Flexible Source Cable (female end)                      HP 08513-60009</p> <p><b>Adapter (HP 8341A only)</b> - Type N (Male)-to-SMA (Male)                      HP 1250-1894</p> <p><b>Wrench</b> - 3.5mm torque wrench, 5/16-inch open-end,                      set to 8 in-lb, HP 1250-1863</p>
12.	<p>Connect  <b>HP 85102A: power line module</b> to <b>ac power source</b>                      (below J2 IF Display                      Interconnect)</p>
13.	<p>Connect  <b>HP 85101A: ac receptacle</b> to <b>ac power source</b>                      (far right, lower rear panel)</p>
14.	<p>Connect  <b>Test Set: power line module</b> to <b>ac power source</b>                      (far left, lower rear panel)</p> <p><b>Cables</b> - AC Power Cord, HP 8120-1348 (USA and Canada).                      Rack-mounted installations use special cord.                      See Table 2-9 for other applications.</p>

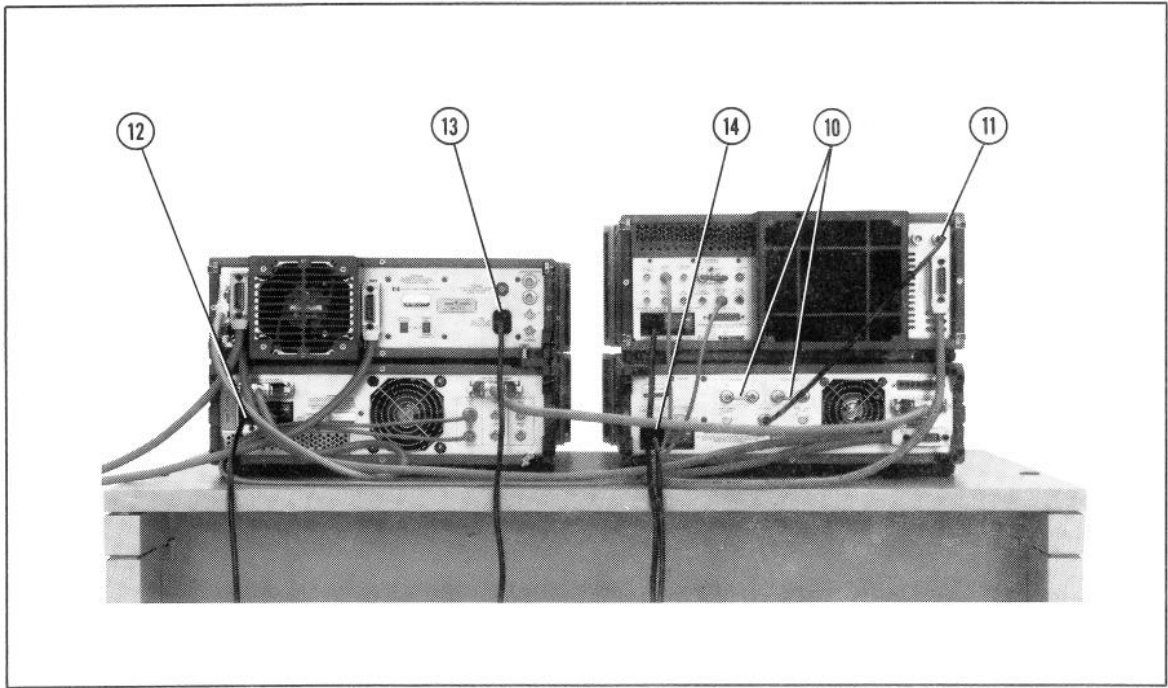

*Figure 2-11. System Interconnections, HP 8340A/41A Source (3)*

<b>INTERCONNECTION SEQUENCE (HP 8350B SOURCE) - 1</b>	
1.	<p>Connect  <b>HP 8350B power line module</b> to ac power source                      (far right, rear panel)</p> <p><b>Cable</b> - AC Power Cord, HP 8120-1348 (USA and Canada).                      Rack-mounted installations use special cord.                      See Table 2-9 for other applications.</p> <p>Set HP 8350B switch to ON</p>
2.	<p>Connect  <b>HP 8350B: STOP SWEEP</b> to <b>HP 85102A: SOURCE                      STOP SWEEP</b></p> <p>(left of PROGRAMMING CONNECTOR) (below and right of fan)</p> <p><b>Cable</b> - BNC, HP 8120-2582</p>
3.	<p>Connect  <b>HP 8350B: SWEEP OUT/IN</b> to <b>HP 85102A: SOURCE                      SWEEP IN 0-10V</b></p> <p>(below and right of fan) (right of fan)</p> <p><b>Cable</b> - BNC, HP 8120-2582</p>
4.	<p>Connect  <b>Test Set: J12 8510 SYSTEM                      BUS connector</b> to <b>HP 85101A: 8510                      INTERCONNECT</b></p> <p>(below SYSTEM BUS ADDRESS switch) (near and left of fan)</p> <p><b>Cable</b> - HP-IB, HP 8120-3445 (Model 10833A)</p>
5.	<p>Connect  <b>HP 8350B: HP INTERFACE                      BUS connector</b> to <b>Test Set: J12 8510                      SYSTEM BUS connector</b></p> <p>(left of fan) (below SYSTEM BUS ADDRESS switch)</p> <p><b>Cable</b> - HP-IB, HP 8120-3445 (Model 10833A)</p>
	<i>continued</i> →

**ELECTRICAL INTERCONNECTIONS:  
SYSTEMS USING AN HP 8350B SWEEP OSCILLATOR**

Figures 2-12 through 2-14 show the electrical interconnections to be made if the source used in the system is an HP 8350B sweep oscillator. Instructions for making instrument interconnections if the source is an HP 8340A/41A synthesized sweeper are given in the preceding section of this manual.

The instruments in Figures 2-9 through 2-11 are arranged in Configuration B using the HP 8350B sweep oscillator as the source (Figure 2-5). The same connections should be made in the same order if another HP 8350B bench configuration is used and in all rack-mounted HP 8350B installations.

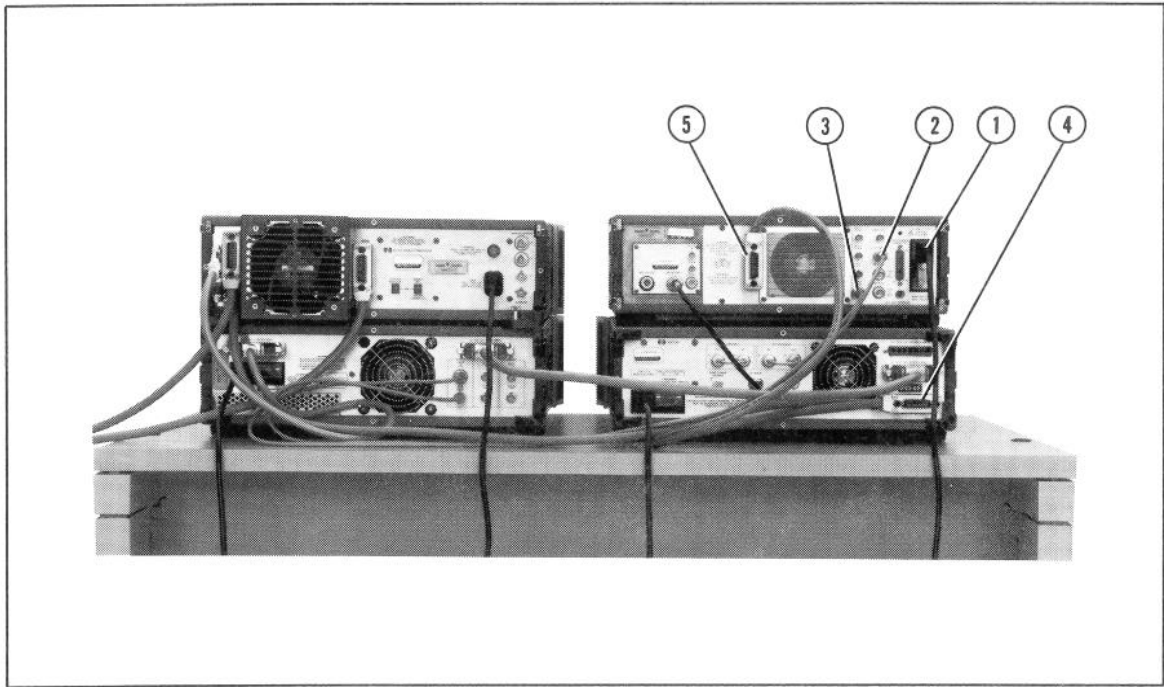

*Figure 2-12. System Interconnections, HP 8350B Source (1)*

INTERCONNECTION SEQUENCE (HP 8350B SOURCE) - 2	
6.	<p>Connect  <b>HP 85102A: J2 IF-DISPLAY INTERCONNECT</b> to <b>HP 85101A IF-DISPLAY INTERCONNECT</b></p> <p>(above power line module) (away and left of fan)</p> <p><b>Cable</b> - IF/Display Interconnect Cable, HP 08510-60101</p>
7.	<p>Connect  <b>Plotter or Printer (if used)</b> to <b>HP 85101A: 8510 SYSTEM BUS connector</b></p> <p>(near and left of fan)</p> <p><b>Cable</b> - HP-IB. Route cable through brush seal on side of rack cabinet in rack-mounted installations.</p>
8.	<p>Connect  <b>HP 85102A: J1 TEST SET INTERCONNECT</b> to <b>Test Set: J11 TEST SET INTERCONNECT</b></p> <p>(right of fan) (above SYSTEM BUS ADDRESS switch)</p> <p><b>Cable</b> - Test Set-IF Interconnect Cable, HP 08510-60102</p>
9.	<p>Connect  <b>Controller: HP-IB (if used)</b> to <b>HP 85101A: HP-IB connector</b></p> <p>(right of fan)</p> <p><b>Cable</b> - HP-IB. Route cable through brush seal on side of rack cabinet in rack-mounted installations.</p>
10.	<p>Connect  <b>Test Set: Extension A, Extension B</b>  (J2 to J3 <i>and</i> J4 to J5: connect both cables)</p> <p><b>Cables</b> - Hardline Port Extension Cables,  HP 08512-20019 (short) <i>or</i> HP 08514-20013 (long).  See page 2-26.</p> <p><b>Wrench</b> - 3.5mm torque wrench, 5/16-inch open-end,  set to 8 in-lb, HP 1250-1863</p>
	<i>continued</i> →

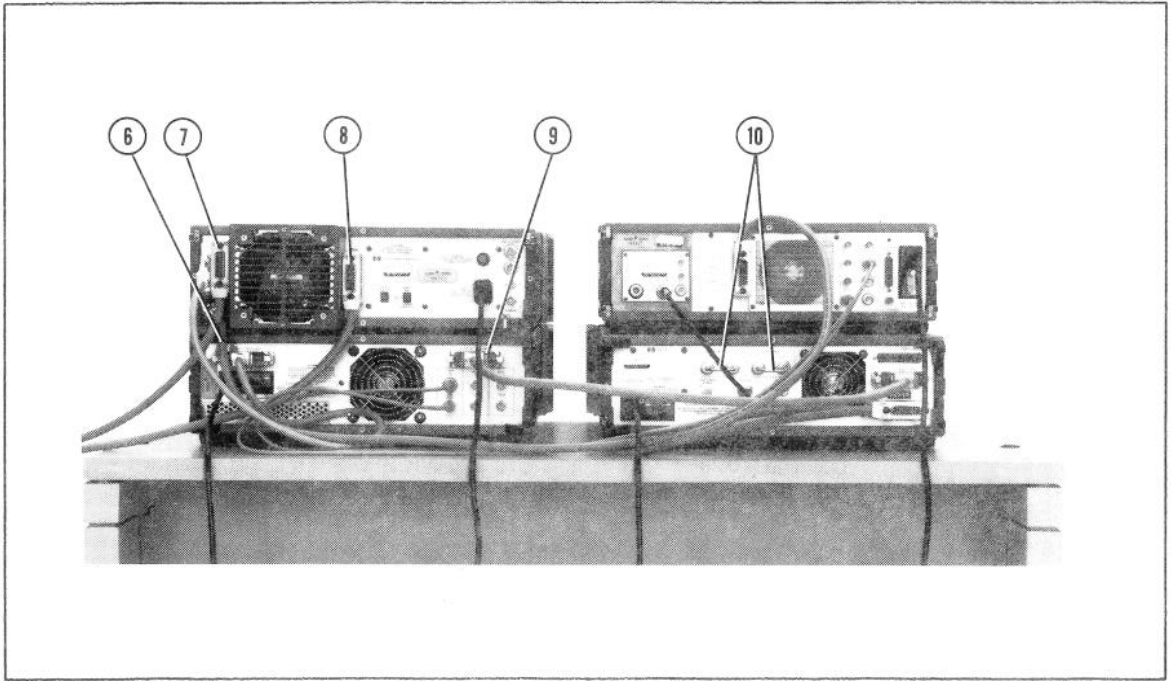

*Figure 2-13. System Interconnections, HP 8350B Source (2)*

<b>INTERCONNECTION SEQUENCE (HP 8350B SOURCE) - 3</b>	
11.	<p>Connect at <b>RF OUTPUT</b> connector, <b>HP 835xx-series RF plug-in</b>  (HP 8350B plug-in, rear panel)</p> <p><b>Adapter</b> - Type N (Male)-to-SMA (Male), HP 1250-1894</p> <p>Required only if plug-in is equipped with Option 004 Type N female RF Output Connector rear panel power output.</p>
12.	<p>Connect <b>HP 835xx-series RF plug-in</b>      to      <b>Test Set: RF INPUT</b> <b>RF OUTPUT</b></p> <p>(HP 8350B plug-in, rear panel)      (below reference port extension cable connections)</p> <p><b>Cable</b> - Flexible source cable (female end) HP 08513-60009</p> <p><b>Wrench</b> - 3.5mm torque wrench, 5/16-inch open-end, set to 8 in-lb, HP 1250-1863</p>
13.	<p>Connect <b>HP 85102A: power line module</b> to      <b>ac power source</b></p> <p>(below J2 IF Display Interconnect)</p>
14.	<p>Connect <b>HP 85101A: ac receptacle</b>      to      <b>ac power source</b></p> <p>(far right, lower rear panel)</p>
15.	<p>Connect <b>Test Set: power line module</b>      to      <b>ac power source</b></p> <p>(far left, lower rear panel)</p> <p><b>Cables</b> - AC Power Cord, HP 8120-1348 (USA and Canada). Rack-mounted installations use special cord. See Table 2-9 for other applications.</p>



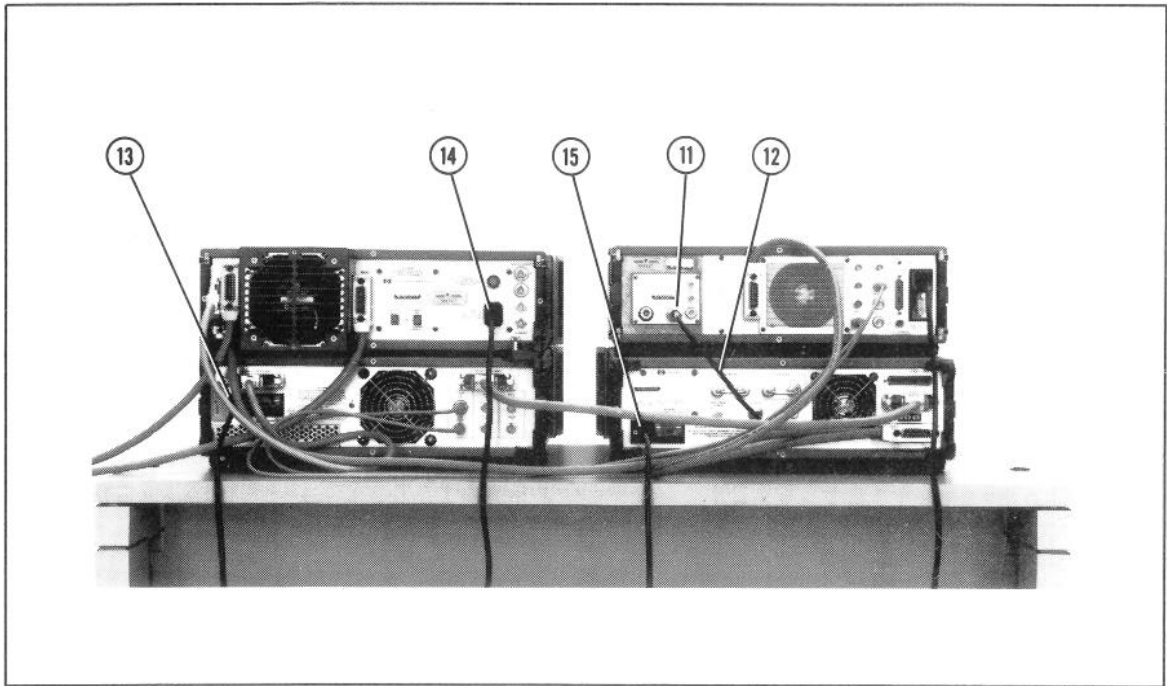

*Figure 2-14. System Interconnections, HP 8350B Source (3)*

## POWER-ON SEQUENCE

Power should be applied to the instruments in the HP 8510 system in the following order. Note that the HP 8510 network analyzer itself should be turned on last, in order for it to gain control of the instruments connected to the 8510 system bus.

### WARNING

Before applying ac power to any instruments or to the system rack, be sure that the ac power inputs of all instruments are set to the correct ac line voltage and that correct fuses have been installed.

Also make sure that the ac power outlet to be used is properly grounded and able to supply the maximum power required for the installation.

Failure to observe these precautions could result in serious personal injury or major damage to the instruments or both.

Apply power to the instruments in the following order:

- SOURCE : HP 8340A/41A or HP 8350B
- TEST SET : HP 8511A - HP 8515A
- SYSTEM PERIPHERALS : PLOTTER (if used)  
PRINTER (if used)
- NETWORK ANALYZER : LINE switch, front panel of  
HP 85102A IF detector

Power to both the HP 85101A display/processor and the HP 85102A IF detector is controlled by the LINE switch on the front panel of the IF detector if the line switch on the rear panel of the display/processor is set to SYSTEM CONTROLLED. If the display/processor does not come on, check the position of this rear-panel switch first.

If an external controller is used as part of the HP 8510 system, the above power-on steps should be completed before turning on power to the controller peripherals and the controller itself:

- CONTROLLER PERIPHERALS
- CONTROLLER

## STORAGE AND SHIPMENT

Table 2-4 gives the environmental requirements for storage of the HP 85101A display/processor, HP 85102A IF detector, and the HP 8511A - HP 8515A test sets. For similar information on sources and peripherals used in HP 8510 systems consult the Operating and Service manuals for those instruments.

### SHIPMENT

If it is necessary to ship any of the instruments in the HP 8510 system, pack each instrument separately and use the original packaging materials if possible. Figure 2-1 will be helpful in repacking some instruments. Containers and materials used for factory shipments are also available, through any Hewlett-Packard office.

If an instrument is being returned to Hewlett-Packard for service, please complete and attach a blue service tag indicating the nature of the problem and who to contact for more information about the service required. Identify the instrument by model number and full serial number and list the other HP 8510 system instruments it is being used with. A supply of service tags is included with this Installation manual.

These general instructions should be followed whenever instruments are packed for shipping:

Wrap the instrument in heavy paper or plastic. If the instrument is being returned to Hewlett-Packard for service, complete a blue service tag and attach it to the instrument.

Place the wrapped instrument in a strong shipping container. A double-wall carton made of 350-pound test material is adequate.

Place enough shock-absorbing material around all sides of the instrument to provide a firm cushion and prevent any movement of the instrument inside the container. A three-inch to four-inch layer is generally sufficient.

Seal each shipping container carefully and mark it FRAGILE to ensure careful handling.

Instruments installed in the HP 85043A system rack must be removed from the rack before shipping. Unlike some rack systems, the HP 85043A system rack cannot be used for shipment, and in storage the rack must be kept in its normal upright position. *Do not store or install instruments in the rack when it is on its side or its back. Major damage to the instruments and to the rack can occur.*



## REGIONAL SALES AND SERVICE OFFICES

### **NORTH/CENTRAL AFRICA**

Hewlett-Packard S.A.  
7, Rue du Bois-du-Lan  
CH-1217 **MEYRIN 2**, Switzerland  
Tel: (022) 83 12 12  
Telex: 27835 hpse  
Cable: HEWPACKSA Geneve

### **ASIA**

Hewlett-Packard Asia Ltd.  
6th Floor, Sun Hung Kai Centre  
30 Harbour Rd.  
G.P.O. Box 795

### **HONG KONG**

Tel: 5-832 3211

*After Jan. 1, 1984*

47th Floor, China Resources Bldg.  
26 Harbour Rd., Wanchai

### **HONG KONG**

Telex: 66678 HEWPA HX  
Cable: HEWPACK HONG KONG

### **CANADA**

Hewlett-Packard (Canada) Ltd.  
6877 Goreway Drive  
**MISSISSAUGA**, Ontario L4V 1M8  
Tel: (416) 678-9430  
Telex: 610-492-4246

### **MEDITERRANEAN AND MIDDLE EAST**

Hewlett-Packard S.A.  
Mediterranean and Middle East  
Operations  
Atrina Centre  
32 Kifissias Ave.  
Paradissos-Amarousion, **ATHENS**  
Greece  
Tel: 682 88 11  
Telex: 21-6588 HPAT GR  
Cable: HEWPACKSA Athens

### **EASTERN EUROPE**

Hewlett-Packard Ges.m.b.h.  
Liebigasse 1  
P.O. Box 72  
A-1222 **VIENNA**, Austria  
Tel: (222) 2365110  
Telex: 1 3 4425 HEPA A

### **NORTHERN EUROPE**

Hewlett-Packard S.A.  
Uilenstede 475  
P.O. Box 999  
NL-1180 AZ **AMSTELVEEN**  
The Netherlands  
Tel: 20 437771

### **SOUTH EAST EUROPE**

Hewlett-Packard S.A.  
7, Rue du Bois-du-Lan  
CH-1217 **MEYRIN 2**, Switzerland  
Tel: (022) 83 12 12  
Telex: 27835 hpse  
Cable HEWPACKSA Geneve

### **OTHER EUROPE**

Hewlett-Packard S.A.  
P.O. Box  
150, Rte du Nant-D'Avril  
CH-1217 **MEYRIN 2**, Switzerland  
Tel: (022) 83 8111  
Telex: 22486 hpsa  
Cable: HEWPACKSA Geneve

### **EASTERN USA**

Hewlett-Packard Co.  
4 Choke Cherry Road  
**ROCKVILLE**, MD 20850  
Tel: (301) 258-2000

### **MIDWESTERN USA**

Hewlett-Packard Co.  
5201 Tollview Drive  
**ROLLING MEADOWS**, IL 60008  
Tel: (312) 255-9800

### **SOUTHERN USA**

Hewlett-Packard Co.  
2000 South Park Place  
P.O. Box 105005  
**ATLANTA**, GA 30348  
Tel: (404) 955-1500

### **WESTERN USA**

Hewlett-Packard Co.  
3939 Lankershim Blvd.  
P.O. Box 3919  
**LOS ANGELES**, CA 91604  
Tel: (213) 506-3700

### **OTHER INTERNATIONAL AREAS**

Hewlett-Packard Co.  
Intercontinental Headquarters  
3495 Deer Creek Road  
**PALO ALTO**, CA 94304  
Tel: (415) 857-1501  
Telex: 034-8300  
Cable: HEWPACK



HP Part Number 08510-90010  
Microfiche Part Number 08510-90011

Printed in U.S.A.