

Agilent PNA Family Microwave Network Analyzers

Configuration Guide

This configuration guide describes standard configurations, options, accessories, upgrade kits and compatible peripherals for the PNA Family microwave network analyzers. This guide should be used with the *Agilent PNA Family data sheets* for a complete description of these analyzers.

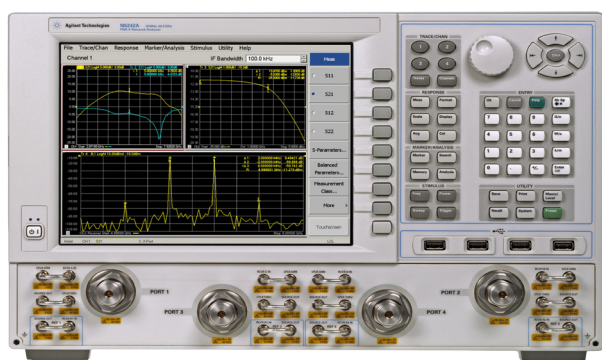

PNA-X Series

N5241A	10 MHz to 13.5 GHz
N5242A	10 MHz to 26.5 GHz
N5244A	10 MHz to 43.5 GHz
N5245A	10 MHz to 50 GHz
N5247A	10 MHz to 67 GHz

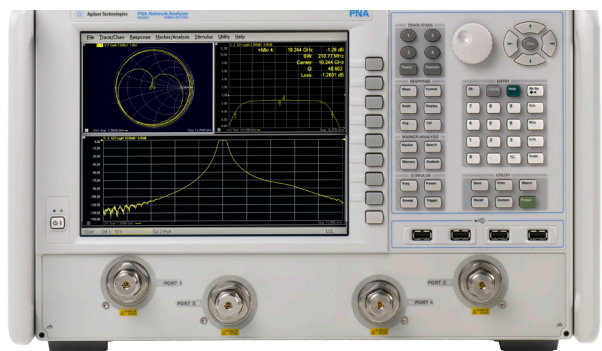

PNA Series

N5221A	10 MHz to 13.5 GHz
N5222A	10 MHz to 26.5 GHz
N5224A	10 MHz to 43.5 GHz
N5225A	10 MHz to 50 GHz
N5227A	10 MHz to 67 GHz

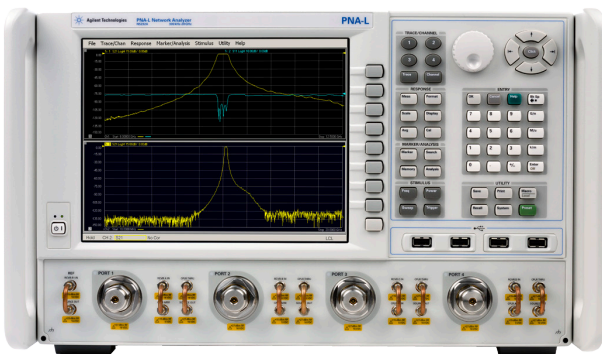

PNA-L Series

N5239A	300 kHz to 8.5 GHz
N5231A	300 kHz to 13.5 GHz
N5232A	300 kHz to 20 GHz
N5234A	10 MHz to 43.5 GHz
N5235A	10 MHz to 50 GHz

Table of Contents

PNA Family Network Analyzer Configurations	4
Test set and power configuration options	4
Application options	5
Accessories, calibration options	6
PNA-X Series test set and power configuration options	7
PNA Series test set and power configuration options	9
PNA-L Series test set and power configuration options	11
PNA Family Application Options	12
Measurement applications	12
Noise figure options	13
Pulse, antenna, mm-wave	16
Accessories	17
PNA Family Network Analyzer Upgrade Kits	18
Frequency, test ports, test set and power configurations	18
Application options	19
Upgrade paths	20
Applications	21
Material measurements	21
Signal integrity measurements	21
Multiport measurements	21
Millimeter-wave measurements	22
Measurement Accessories	23
Calibration kits, cables, adapters	23
For devices with 1.0 mm connectors	24
For devices with 1.85 mm connectors	24
For devices with 2.4 mm connectors	25
For devices with K (2.92 mm) connectors	25
For devices with 3.5 mm or SMA connectors	27
For devices with Type-N connectors	28
For devices with 7 mm connectors	29
For devices with waveguide	29
Verification kits	30
General Accessories	31
Spare drive	31
Probe	31
Power meters and sensors	31
Comb generators	31
Amplifiers	31
Couplers	31
Equipment rack accessories	31
Monitors	31
Printers	31
Interface cables	31

Agilent offers the following options for all PNA Family network analyzers

Certification options

Commercial calibration certification with test data (Option UK6)

Complete set of measurements which tests unit to manufacturer's published specifications. Includes calibration label, calibration certificate, and data report. Conforms to ISO 9001.

ISO 17025 compliant calibration (Option 1A7)

Complete set of measurements which tests unit to manufacturer's published specifications. Includes calibration label, ISO 17025 calibration certificate, and data report, measurement uncertainties and guardbands on all customer specifications. Conforms to ISO 17025 and ISO 9001.

ANSI Z540 compliant calibration (Option A6J)

Complete set of measurements which tests unit to manufacturer's published specifications. Includes pre- and post-adjustment data with measurement uncertainty information compliant to the ANSI/NCSL Z540 standard.

Warranty and service

1-, 3-, and 5-year warranty and service plans are available at the time of instrument purchase. Standard warranty is 1 year.

Documentation

The PNA Series instruments are equipped with an Online Help system available within the instrument in English only. All PNA documentation is available on the web: www.na.tm.agilent.com/pna

Calibration Software Licenses

Perpetual license for built-in performance test software for Agilent inclusive cal (Option 897)

Adds built-in performance testing and calibration software for self-maintainers. Requires additional equipment. See the analyzer's Service Guide for more information on equipment required.

Perpetual license for built-in performance test software for Standards compliant cal (Option 898)

Adds built-in performance testing and calibration software for self-maintainers. Requires additional equipment. See the analyzer's Service Guide for more information on equipment required.

PNA Family Network Analyzer Configurations

PNA-X Series	PNA Series	PNA-L Series
N5241A 10 MHz to 13.5 GHz	N5221A 10 MHz to 13.5 GHz	N5239A 300 kHz to 8.5 GHz
N5242A 10 MHz to 26.5 GHz	N5222A 10 MHz to 26.5 GHz	N5231A 300 kHz to 13.5 GHz
N5244A 10 MHz to 43.5 GHz	N5224A 10 MHz to 43.5 GHz	N5232A 300 kHz to 20 GHz
N5245A 10 MHz to 50 GHz	N5225A 10 MHz to 50 GHz	N5234A 10 MHz to 43.5 GHz
N5247A 10 MHz to 67 GHz	N5227A 10 MHz to 67 GHz	N5235A 10 MHz to 50 GHz

Test set and power configuration options

Choose one test set and power configuration option. Option 2xx indicates two test ports. Option 4xx indicates four test ports. To add options to a product, order the corresponding item number (N52xxA-xxx).

Description	Configurable Test Set	Source Attenuators	Receiver Attenuators	Bias-tees	Internal Second Source	Internal Combiner	Mechanical Switches	Additional Information
PNA-X Series								
Option 200	•							
Option 200, H85, 285 ¹	•	•	•					Not available on 67 GHz model
Option 200, 219	•	•	•	•				
Option 200, H85, 285, 224 ¹	•	•	•		•	•	•	Requires Option 080 Not available on 67 GHz model
Option 200, 219, 224	•	•	•	•	•	•	•	Requires Option 080
Option 400	•				•			Option 080 recommended
Option 400, H85, 485 ¹	•	•	•		•			Option 080 recommended Not available on 67 GHz model
Option 400, 419	•	•	•	•	•			Option 080 recommended
Option 400, H85, 485, 423 ¹	•	•	•		•	•	•	Requires Option 080 Not available on 67 GHz model
Option 400, 419, 423	•	•	•	•	•	•	•	Requires Option 080
PNA Series								
Option 200								
Option 201	•							
Option 217	•	•	•					Not available on 67 GHz model
Option 219	•	•	•	•				
Option 400					•			Option 080 recommended
Option 401	•				•			Option 080 recommended
Option 417	•	•	•		•			Option 080 recommended Not available on 67 GHz model
Option 419	•	•	•	•	•			Option 080 recommended
PNA-L Series								
Option 200								
Option 216	•	•						
Option 400								Available on only N5231A/2A
Option 416 ²	•	•						Available on only N5231A/2A

- Order special model N524xAS instead of N524xA. Order N524xA-xxx items for other standard options. Option H85 requires Option 285 or 485 which includes the extended power range of Option 219 or 419; therefore these options cannot be combined.
- Adds one source attenuator to be shared with all test ports.

PNA Family Network Analyzer Configurations *(continued)*

PNA-X Series	PNA Series	PNA-L Series
N5241A 10 MHz to 13.5 GHz	N5221A 10 MHz to 13.5 GHz	N5239A 300 kHz to 8.5 GHz
N5242A 10 MHz to 26.5 GHz	N5222A 10 MHz to 26.5 GHz	N5231A 300 kHz to 13.5 GHz
N5244A 10 MHz to 43.5 GHz	N5224A 10 MHz to 43.5 GHz	N5232A 300 kHz to 20 GHz
N5245A 10 MHz to 50 GHz	N5225A 10 MHz to 50 GHz	N5234A 10 MHz to 43.5 GHz
N5247A 10 MHz to 67 GHz	N5227A 10 MHz to 67 GHz	N5235A 10 MHz to 50 GHz

Application options

To add options to a product, order the corresponding item number (N52xxA-xxx).

Description	For PNA-X Series	For PNA Series	For PNA-L Series	Additional Information
Measurement application				
Time-domain measurements	N524xA-010	N522xA-010	N523xA-010	
Noise figure measurements using standard receivers ¹	N524xA-028	N522xA-028	n/a	Requires Option 080. For measuring frequency converters, requires Option 082 or 083. Not available with N522xA-200 and -400
Fully-corrected noise figure measurements ¹	N524xA-029	n/a	n/a	Requires Option 080 and for N5241/42A, one of Options 219, 224, 419, 423 or H85. For N5244/45/47A, requires Option 224 or 423. On N5247A, noise receivers work up to 50 GHz only. For measuring frequency converters, requires Option 082 or 083.
Frequency offset ²	N524xA-080	N522xA-080	N523xA-080	
Scalar-calibrated converter measurements ³	N524xA-082	N522xA-082	N523xA-082	Requires Option 080
Vector- and scalar-calibrated converter measurements ^{3, 4}	N524xA-083	N522xA-083	n/a	Requires Option 080
Embedded LO measurements	N524xA-084	N522xA-084	n/a	Requires Option 082 or Option 083. Also works with Options 028, 029, 086 and 087
Gain compression application	N524xA-086	N522xA-086	n/a	For measuring frequency converters, requires Option 082 or 083
Intermodulation distortion application ⁵	N524xA-087	N522xA-087	n/a	Requires Option 080 For measuring frequency converters, requires Option 082 or 083. Not available with N522xA-200 and 400
Source phase control	N524xA-088	N522xA-088	n/a	Not available with N522xA-200
Integrated true-mode stimulus application	N524xA-460	N522xA-460	n/a	Requires one of Options 400, 401, 417, 419 or 423
N-port capabilities ⁶	N524xA-551 ⁷	N522xA-551	N523xA-551	Not available with N522xA-200, -400, N523xA-200 and -400

- For N522xA and N5241/42A, vector-noise-corrected measurements require an ECal for use as an impedance tuner. For N5244/45/47A with Option 029, an internal tuner is included. For calibration, Option 028 requires a power meter, and Option 029 requires either a power meter or a 346-series noise source (Agilent 346C or 346C-K01 recommended). All options require a power meter for measuring mixers and converters.
- Option 080 is required to configure an external source using External Device Configuration dialog.
- Option 082 is a subset of Option 083; therefore, they cannot be ordered together.
- For vector mixer calibration, a configurable test set is required for connecting a reference mixer (when ordered with N522xA-200 or -400, Option 083 adds phase measurements using SMC+Phase only).
- Option 087 can be ordered without N524xA-224 or N524xA-423, but may require external equipment such as a signal generator and a combiner. Refer to page 12 for more details.
- When ordering a test set, select an appropriate interface kit. Refer to page 21 Multipoint Measurements section for more details.
- When configuring N524xA as a multipoint analyzer using Option 551 and a multipoint test set, the combiner feature of Option 224 or 423 is temporarily disabled. When configuring N524xA as a standalone analyzer, the combiner feature is enabled.

PNA Family Network Analyzer Configurations *(continued)*

PNA-X Series

N5241A 10 MHz to 13.5 GHz
 N5242A 10 MHz to 26.5 GHz
 N5244A 10 MHz to 43.5 GHz
 N5245A 10 MHz to 50 GHz
 N5247A 10 MHz to 67 GHz

PNA Series

N5221A 10 MHz to 13.5 GHz
 N5222A 10 MHz to 26.5 GHz
 N5224A 10 MHz to 43.5 GHz
 N5225A 10 MHz to 50 GHz
 N5227A 10 MHz to 67 GHz

PNA-L Series

N5239A 300 kHz to 8.5 GHz
 N5231A 300 kHz to 13.5 GHz
 N5232A 300 kHz to 20 GHz
 N5234A 10 MHz to 43.5 GHz
 N5235A 10 MHz to 50 GHz

Application options *(continued)*

To add options to a product, order the corresponding item number (N52xxA-xxx).

Description	For PNA-X Series	For PNA Series	For PNA-L Series	Additional Information
Pulse, antenna, mm-wave				
Pulsed-RF measurements	N524xA-008	N522xA-008	n/a	Requires Option 025
Add IF inputs	N524xA-020	N522xA-020	n/a	
Add pulse modulator to internal 1st source	N524xA-021	N522xA-021	n/a	
Add pulse modulator to internal 2nd source	N524xA-022	N522xA-022	n/a	Requires one of Option 224, 400, 401, 417, 419, or 423
Add four internal pulse generators	N524xA-025	N522xA-025	n/a	
Fast CW sweep	N524xA-118	N522xA-118	n/a	
Nonlinear vector network analysis¹				
Nonlinear component characterization	N524xA-510	n/a	n/a	Requires Options 419 and 080, or 400, H85 and 080
Nonlinear X-parameters ²	N524xA-514	n/a	n/a	Requires Options 423 and 510, requires MXG or PSG except 10 MHz tone-spacing
Nonlinear pulse envelope domain	N524xA-518	n/a	n/a	Requires Options 021, 025 and 510
Arbitrary load-impedance X-parameters	N524xA-520	n/a	n/a	Requires Option 514, requires MXG or PSG except 10 MHz tone-spacing

Accessories, calibration options

To add options to a product, order the corresponding item number (N52xxA-xxx).

Description	For PNA-X Series	For PNA Series	For PNA-L Series	Additional Information
Accessories				
Rack mount kit for use without handles	N524xA-1CM	N522xA-1CM	N523xA-1CM	
Rack mount kit for use with handles	N524xA-1CP	N522xA-1CP	N523xA-1CP	
Pulse I/O adapter	N1966A	N1966A	n/a	
Calibration software				
Perpetual license for built-in performance test software for Agilent inclusive calibration ³	N524xA-897	N522xA-897	N523xA-897	
Perpetual license for built-in performance test software for standard compliant calibration ³	N524xA-898	N522xA-898	N523xA-898	
Calibration documentation				
ISO 17025 compliant calibration	N524xA-1A7	N522xA-1A7	N523xA-1A7	
Commercial calibration certificate with test data	N524xA-UK6	N522xA-UK6	N523xA-UK6	
ANSI Z540 compliant calibration	N524xA-A6J	N522xA-A6J	N523xA-A6J	

1. To configure NVNA, requires two comb generators with power supplies, Agilent calibration kits (mechanical or ECal), power meter and sensor or USB power sensor. Requires EXG, MXG or PSG for X-parameter extraction (PNA-X 10 MHz reference output can be used for 10 MHz tone-spacing applications).
2. X-parameters is a trademark of Agilent Technologies.
3. Additional hardware required. Please refer to the analyzer's Service Guide for required service test equipment.

PNA-X Series test set and power configuration options

The PNA-X is an integrated vector network analyzer featuring a built-in S-parameter test set, one or two synthesized sources used for device stimulus, a solid-state drive, USB interfaces, and a 10.4" LCD touch screen display. The N5241A and the N5242A have 50 ohm, ruggedized 3.5 mm (m) test ports. The N5244A and the N5245A have 50 ohm, ruggedized 2.4 mm (m) test ports. The N5247A has 50 ohm, ruggedized 1.85 mm (m) test ports. Included with each instrument is a mouse, keyboard (U.S. style), a 1-year return-to-Agilent service warranty, and one day of on-site productivity assistance (PS-S20-PNA).

A test set and power configuration option is mandatory, choose one of the following:

2-port standard test set and power range (Option 200)

The standard 2-port test set comes with six front-panel access loops. The loops provide access to the signal path between (a) the source output and the reference receiver, (b) the source output and directional coupler thru arm and (c) the coupled arm of the directional coupler and the port receiver. The standard test set also includes a solid-state internal RF transfer switch in the R1 reference-receiver path.

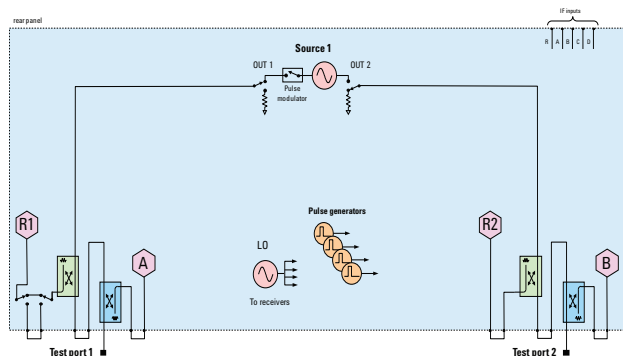

High-power configurable and extended power range (N524xAS Option H85/285)

With extended power range and bias-tees (Option 219), the internal bias-tees limit the maximum test port input power to +30 dBm. The N524xAS Option H85/285 removes the bias-tees between the source attenuators and the test port couplers. This extends the maximum port power that the analyzer can safely handle to +43 dBm. Selecting Option H85/285 adds internal attenuators and cables. The N524xAS Option H85/285 and Option 219 can not be ordered together. Option H85/285 is not available for the N5247A. When ordering, select N524xAS then add items N524xAS-H85, N524xAS-285 and N524xA-200.

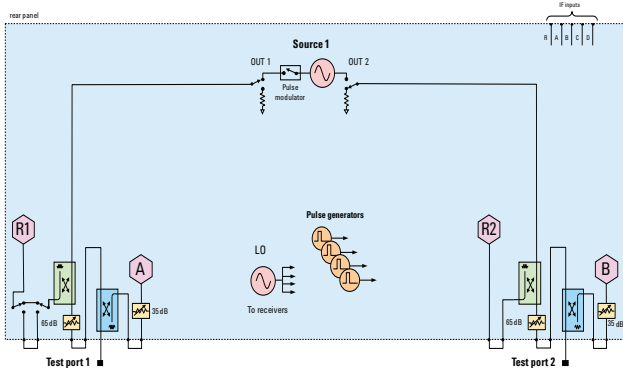

Extended power range and bias-tees (Option 219)

Adds to the standard test set one 65 dB for N5241/42A, 60 dB for N5244/45A, and 50 dB for N5247A source attenuator (set table in 5 dB increments for N5241/42A and 10 dB increments for N5244/45/47A), one 35 dB receiver attenuator (settable in 5 dB increments) for N5241/42/44/45A and 50 dB receiver attenuator (settable in 10 dB increments) for N5247A, and one bias-tee to each test port. Option 219 requires Option 200.

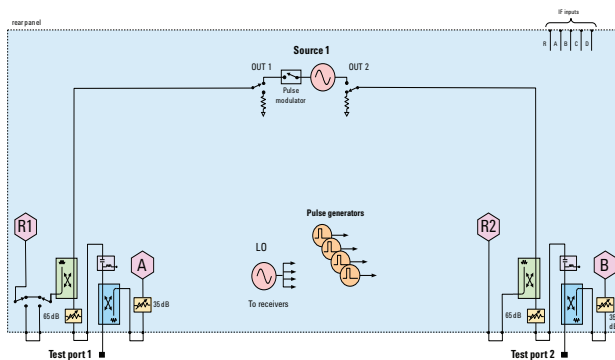

Add an internal second source, a combiner and mechanical switches to 2-port analyzer (Option 224)

Available with 2-port model only, this option adds an internal second source, a combiner and mechanical switches. The internal second source provides an additional signal (fixed or swept) for two-tone third-order-intercept (TOI) and intermodulation testing of amplifiers, or it can be used as a fast swept-LO signal for fixed-IF testing of mixers and converters. The mechanical switches provide increased flexibility by having rear panel access (front panel access for N5247A Source 1 and 2 Out 1) to signal paths for advanced applications. Access to the second source is available through two output connectors on the front panel. Requires Options 200, 219 and 080.

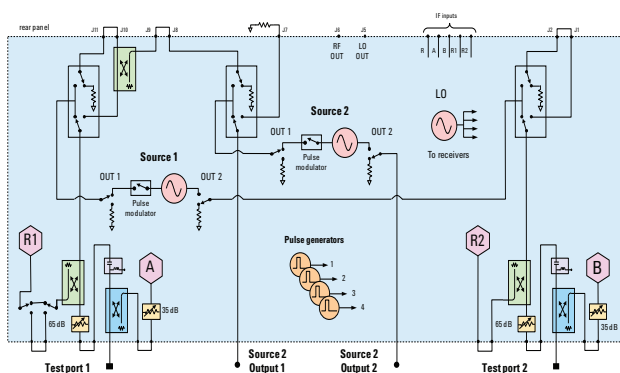

PNA-X Series test set and power configuration options (continued)

4-port standard test set, power range and an internal second source (Option 400)

The standard 4-port test set comes with 12 front-panel access loops and a built-in second source. The loops provide access to the signal path between (a) the source output and the reference receiver, (b) the source output and directional coupler thru arm and (c) the coupled arm of the directional coupler and the port receiver. The internal second source provides an additional signal (fixed or swept) for two-tone third-order-intercept (TOI) and intermodulation testing of amplifiers, or it can be used as a fast swept-LO signal for fixed-IF testing of mixers and converters. With two sources, source 1 is accessible through test ports 1 and 2, and source 2 is accessible through test ports 3 and 4. The standard test set also includes a solid-state internal RF transfer switch in the R1 reference-receiver path. Option 080 is recommended.

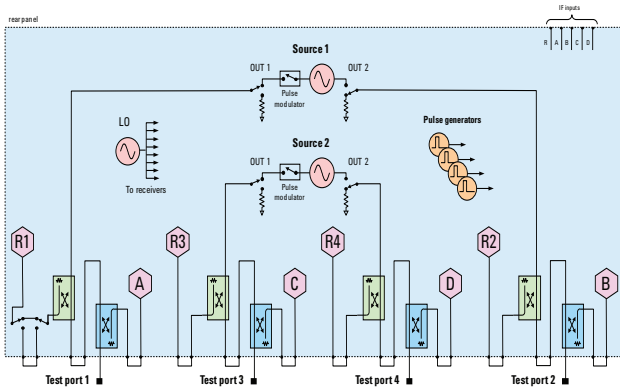

High-power configurable and extended power range (N524xAS Option H85/485)

With extended power range and bias-tees (Option 419), the internal bias-tees limit the maximum test port input power to +30 dBm. The N524xAS Option H85/485 removes the bias-tees between the source attenuators and the test port couplers. This extends the maximum port power that the analyzer can safely handle to +43 dBm. Selecting Option H85/485 adds internal attenuators and cables. The N524xAS Option H85/485 and Option 419 can not be ordered together. Option H85/485 is not available for the N5247A. When ordering, select N524xAS then add items N524xAS-H85, N524xAS-485 and N524xA-400.

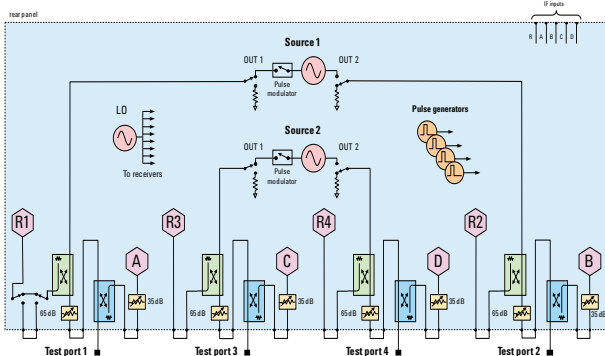

Extended power range and bias-tees (Option 419)

Adds to the standard test set one 65 dB for N5241/52A, 60 dB for N5244/45A, and 50 dB for N5247A source attenuator (settable in 5 dB increments for N5241/42A and 10 dB increments for N5244/45/47A), one 35 dB receiver attenuator (settable in 5 dB increments) for N5241/42/44/45A and 50 dB receiver attenuator (settable in 10 dB increments) for N5247A, and one bias-tee to each test port. Option 419 requires Option 400.

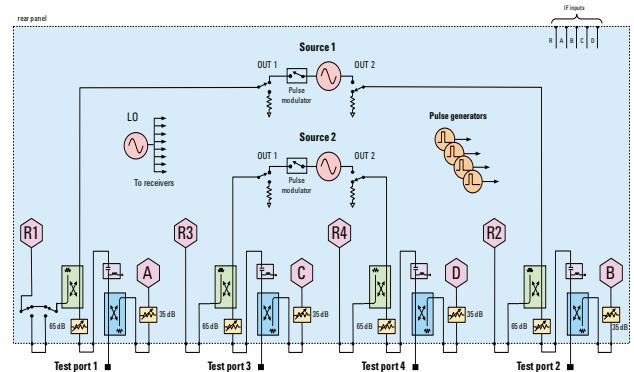

Add an internal combiner and mechanical switches to 4-port analyzer (Option 423)

Available with 4-port model only, this option adds a combiner and mechanical switches. The mechanical switches provide increased flexibility by having rear panel access (front panel access for the N5247A Source 1 and 2 Out 1) to signal paths for advanced applications. Requires Options 400, 419 and 080.

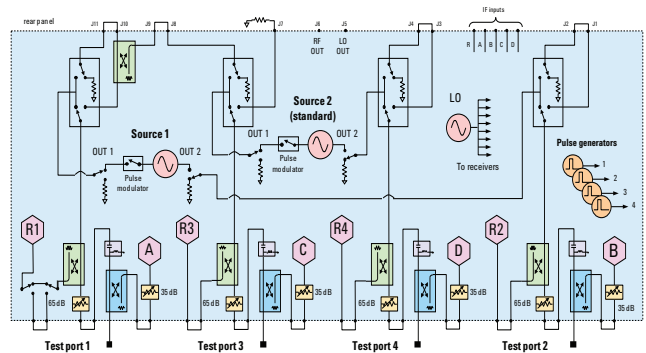

PNA Series test set and power configuration options

The PNA is an integrated vector network analyzer featuring a built-in S-parameter test set, one or two synthesized sources used for device stimulus, a solid-state drive, USB interfaces, and a 10.4" LCD touch screen display. The N5221A and the N5222A have 50 ohm, ruggedized 3.5 mm (m) test ports. The N5224A and the N5225A have 50 ohm, ruggedized 2.4 mm (m) test ports. The N5227A has a 50 ohm, ruggedized 1.85 mm (m) test ports. Included with each instrument is a mouse, keyboard (U.S. style), a 1-year return-to-Agilent service warranty, and one day of on-site productivity assistance (PS-S20-PNA).

A test set and power configuration option is mandatory, choose one of the following:

2-ports, single source, base configuration (Option 200)

The 2-port with base configuration has no front-panel access loops.

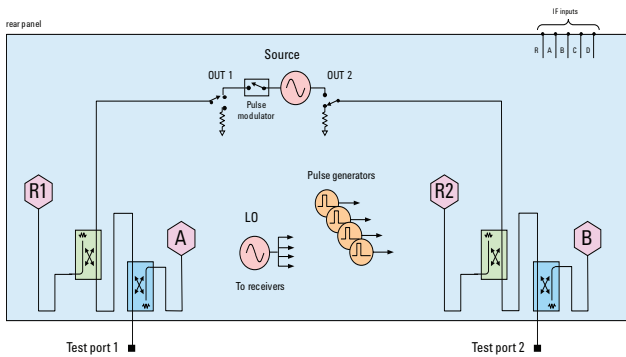

2-ports, single source, with configurable test set (Option 201)

The 2-port configurable test set comes with six front-panel access loops. The loops provide access to the signal path between (a) the source output and the reference receiver, (b) the source output and directional coupler thru arm and (c) the coupled arm of the directional coupler and the port receiver at all ports. Also included is a solid-state internal RF transfer switch in the R1 reference-receiver path.

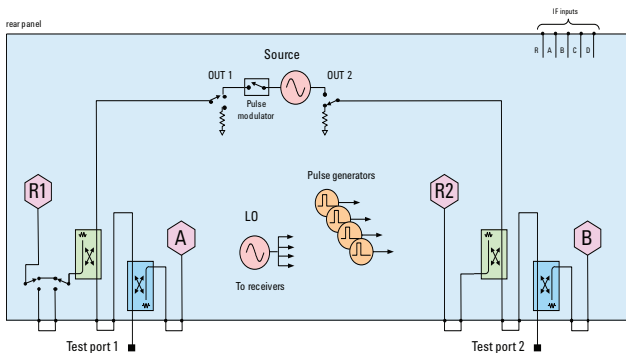

2-ports, single source, with extended power range (Option 217)

The 2-port test set with extended power range comes with a configurable test set, source and receiver attenuators at each port. For N5221/22A, the source attenuators are 65 dB in 5 dB steps and the receiver attenuators are 35 dB in 5 dB steps. For N5224/25A, the source attenuators are 60 dB in 10 dB steps and the receiver attenuators are 35 dB in 5 dB steps. Also included is a solid-state internal RF transfer switch in the R1 reference-receiver path. This configuration is not available on N5227A.

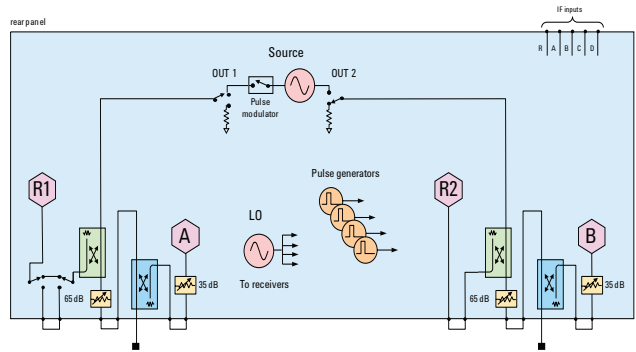

2-ports, single source, with extended power range and bias-tee (Option 219)

The 2-port test set with extended power range and bias-tee comes with a configurable test set, source and receiver attenuators, and bias-tee at each port. For N5221/22A, the source attenuators are 65 dB in 5 dB steps and the receiver attenuators are 35 dB in 5 dB steps. For N5224/25A, the source attenuators are 60 dB in 10 dB steps and the receiver attenuators are 35 dB in 5 dB steps. For N5227A, both source and receiver attenuators are 50 dB in 10 dB steps. Also included is a solid-state internal RF transfer switch in the R1 reference-receiver path.

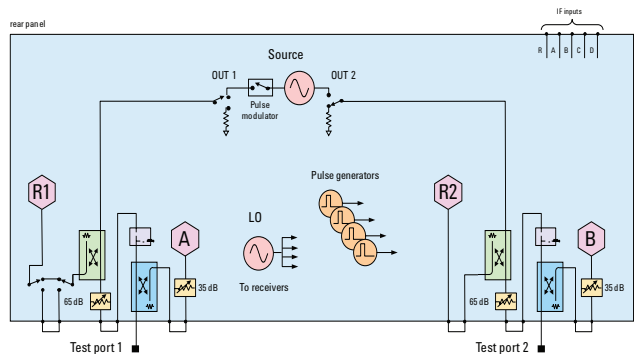

PNA Series test set and power configuration options (continued)

□ 4-ports, dual source, base configuration (Option 400)

The 4-port with base configuration has no front-panel access loops.

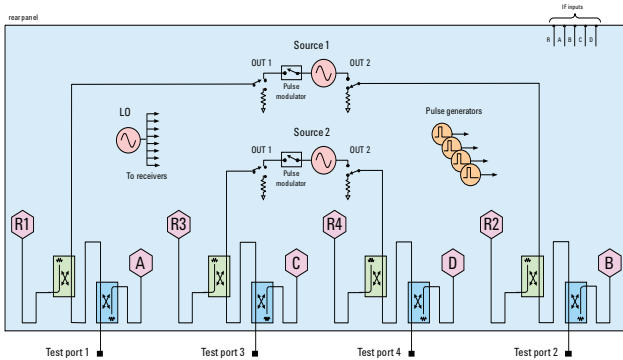

□ 4-ports, dual source, with configurable test set (Option 401)

The 4-port configurable test set comes with two internal sources, twelve front-panel access loops. The loops provide access to the signal path between (a) the source output and the reference receiver, (b) the source output and directional coupler thru arm and (c) the coupled arm of the directional coupler and the port receiver at all ports. Also included is a solid-state internal RF transfer switch in the R1 reference-receiver path.

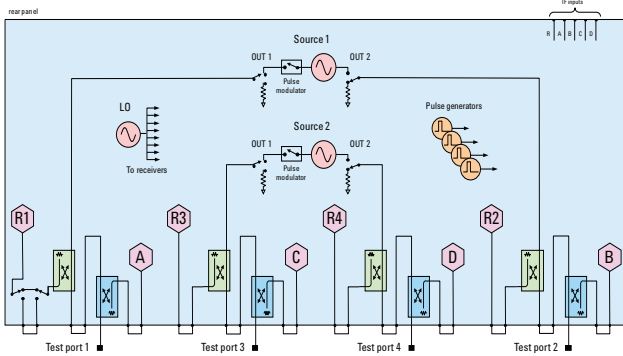

□ 4-ports, dual source, with extended power range (Option 417)

The 4-port test set with extended power range comes with two internal sources, configurable test set, source and receiver attenuators at each port. For N5221/22A, the source attenuators are 65 dB in 5 dB steps and the receiver attenuators are 35 dB in 5 dB steps. For N5224/25A, the source attenuators are 60 dB in 10 dB steps and the receiver attenuators are 35 dB in 5 dB steps. Also included is a solid-state internal RF transfer switch in the R1 reference-receiver path. This configuration is not available on N5227A.

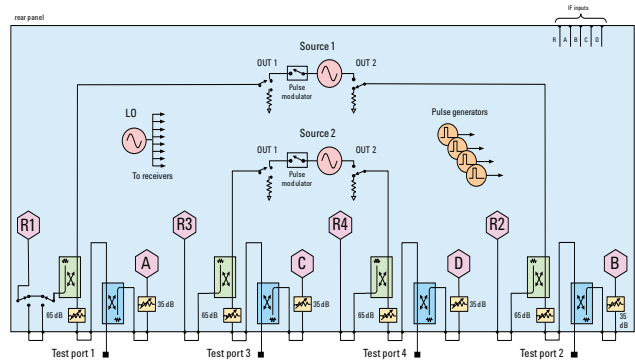

□ 4-ports dual source, with extended power range and bias-tee (Option 419)

The 4-port test set with extended power range and bias-tee comes with two internal sources, configurable test set, source and receiver attenuators, and bias-tee at each port. For N5221/22A, the source attenuators are 65 dB in 5 dB steps and the receiver attenuators are 35 dB in 5 dB steps. For N5224/25A, the source attenuators are 60 dB in 10 dB steps and the receiver attenuators are 35 dB in 5 dB steps. For N5227A, both source and receiver attenuators are 50 dB in 10 dB steps. Also included is a solid-state internal RF transfer switch in the R1 reference-receiver path.

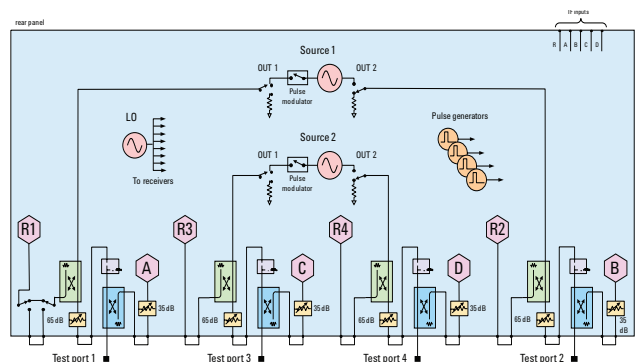

PNA-L Series test set and power configuration options

The PNA-L is an integrated vector network analyzer featuring a built-in S-parameter test set, one synthesized source used for device stimulus, a solid state drive, USB interfaces, and a 10.4" LCD touch screen display. The N5239A, N5231A and the N5232A have 50 ohm, ruggedized 3.5 mm (m) test ports. The N5234A and N5235A have 50 ohm, ruggedized 2.4 mm (m) test ports. Included with each instrument is a mouse, keyboard (U.S. style), and a 1-year return-to-Agilent service warranty. For one day of on-site productivity assistance (not included with instrument purchase), request quantity 1 each PS-S20-PNA.

A test set and power configuration option is mandatory, choose one of the following:

2 ports, single source, base configuration (Option 200)

The 2-port with base configuration has no front-panel access loops.

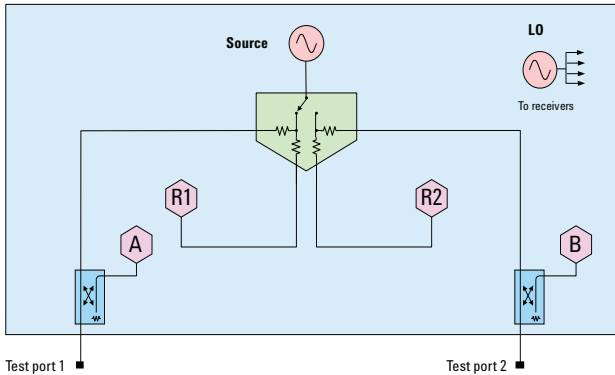

2 ports, single source, with configurable test set and source attenuators (Option 216)

The 2-port test set comes with a configurable test set and source attenuator at each port. The configurable test set adds six front-panel access loops. The loops provide access to the signal path between (a) the source output and the reference receiver, (b) the source output and directional coupler thru arm, and (c) the coupled arm of the directional coupler and the port receiver at all ports. The source attenuators are 60 dB in 10 dB steps.

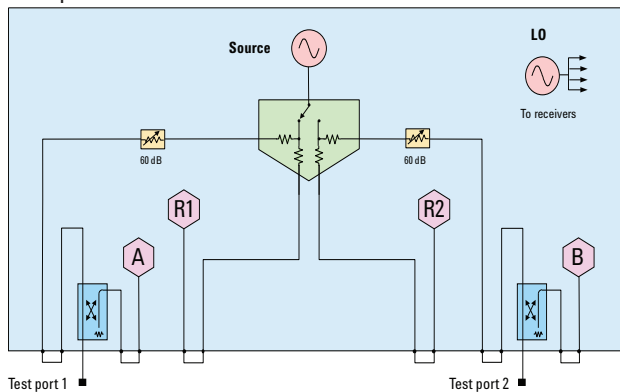

4 ports, single source, base configuration (Option 400)

The 4-port base configuration has no front-panel loops, and is available only on the N5231A and N5232A.

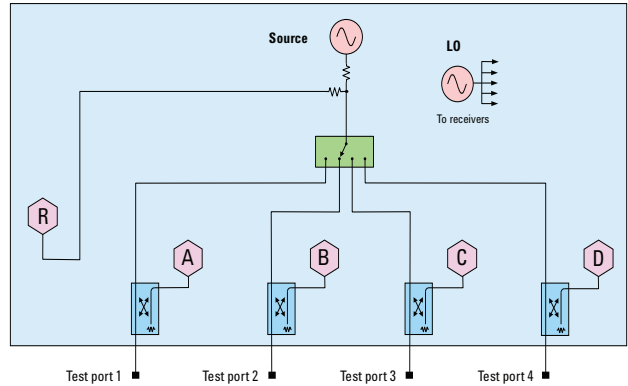

4 ports, single source, with configurable test set and source attenuator (Option 416)

The 4-port test set comes with a configurable test set and one source attenuator to be shared with all ports. The configurable test set adds nine front-panel access loops. The loops provide access to the signal path between (a) the source output and the reference receiver, (b) the source output and directional coupler thru arm at all ports, and (c) the coupled arm of the directional coupler and the port receiver at all ports. The source attenuator is 60 dB in 10 dB steps. This configuration is available on only N5231A and N5232A.

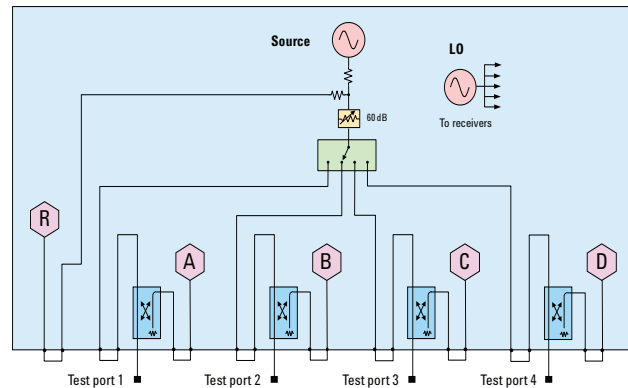

PNA Family Application Options

Measurement applications

Solid black series name indicates the feature is available on that series, while gray series name with strikethrough indicates the feature is not available on that series. For example:

PNA: Available on PNA Series

~~PNA:~~ Not available on PNA Series

Time domain (Option 010)

PNA-X PNA ~~PNA-L~~

This option enables the analyzer to view reflection and transmission responses in time or distance. Use time domain to tune filters, gate out the response of fixtures and cables, characterize the impedance of transmission lines and more. If eye-diagram analysis, W-element modeling or high-speed interconnect testing is required, PLTS N1930B software must be used.

Frequency offset (Option 080)

PNA-X PNA ~~PNA-L~~

This option enables the analyzer to set the source frequency independently from where the receivers are tuned, and is required to configure an external source using External Device Configuration. This ability is important for measuring amplifiers, mixers, and frequency converters.

Scalar-calibrated converter measurements (Option 082)

PNA-X PNA ~~PNA-L~~

With a simple setup and calibration, this application delivers the highest accuracy for scalar conversion-loss/gain measurements by combining one-port and power-meter calibrations to remove mismatch errors. Option 082 provides an intuitive and easy-to-use user interface for setting up mixer and converter measurements, with single or dual conversion stages. It can control the analyzer's built-in source(s) as well as external signal generators for use as LO signals. Supported external sources include the Agilent ESG, PSG, and MXG Series, as well as other SCPI-controlled signal generators. Option 082 requires Option 080, and cannot be ordered with Option 083. It is compatible with Option 084, which enables measurements of converters with internal LOs.

Vector- and scalar-calibrated converter measurements (Option 083)

PNA-X PNA ~~PNA-L~~

This application includes the scalar mixer/converter plus phase (SMC+Phase) measurement class that provides fully calibrated conversion gain/loss, relative phase, and absolute group delay measurements of mixers and converters without the need for reference or calibration mixers. Eliminating the calibration mixer requires a U9391C/F/G comb generator and an external DC power supply capable of sourcing +15 V to 300 mA for U9391C/F or 800 mA for U9391G¹. A vector mixer/converter measurement (VMC) class is also included for measurements with the least amount of trace noise for phase/delay measurements. Option 083 provides an intuitive and easy-to-use user interface for setting up mixer and converter measurements, with single or dual conversion stages. It can control the

analyzer's built-in source(s) as well as external signal generators for use as LO signals. Supported external sources include the Agilent ESG, PSG, and MXG Series, as well as other SCPI-controlled signal generators. Option 083 requires Option 080, and cannot be ordered with Option 082. It is compatible with Option 084, which enables measurements of converters with internal LOs.

Embedded LO measurements (Option 084)

PNA-X PNA ~~PNA-L~~

This option tunes the analyzer's receivers to the output frequency of the converter under test without the need for access to internal LOs or a common reference signal. For converters with embedded LOs, this option requires Option 082 (enables match-corrected conversion loss/gain measurements) or Option 083 (enable absolute group delay measurements). This option also works with Option 086 gain compression application, Option 087 intermodulation distortion application, and Option 028/029/H29 noise figure applications.

Gain compression application (Option 086)

PNA-X PNA ~~PNA-L~~

The gain compression application (GCA) provides input power, output power, gain, and phase at the compression point of an amplifier or frequency converter, over a specified frequency range. GCA's SMART Sweep is very fast and easy-to-use. GCA also includes a guided calibration that corrects for absolute power levels, frequency response, and mismatch errors.

Intermodulation distortion application (Option 087)

PNA-X PNA ~~PNA-L~~

The intermodulation distortion (IMD) application makes it very easy to set up and calibrate swept-IMD measurements of both amplifiers and frequency converters. It controls the frequency and power of internal and external sources and tunes the receivers to the main tones as well as the IMD products in a single measurement channel. The user can sweep either the center frequency of the two stimulus signals, the frequency spacing of the two stimulus signals about a fixed center frequency, or the power of one or both stimulus signals or the power of the LO signal. The analyzer can measure intermodulation distortion products of order 2, 3, 5, 7, or 9, and can display the associated intercept points. In addition, an IM Spectrum mode gives a spectrum-analyzer-like display for confirming or trouble-shooting measurements. Requires Option 080. Not available with PNA Option 200 and 400. When configured with a 2-port PNA or 2-port PNA-X with either Option 200 or 219, an external signal generator and a combiner are required. When configured with a 4-port PNA or 4-port PNA-X with Option 400 or 419, the two internal sources and an unused test port coupler configured as a combiner can be used for two-tone IMD measurements. When configured with PNA-X Option 224 or 423, the two internal sources and internal combiner can be used for two-tone IMD measurements.

1. When using a comb generator as a phase reference for calibration, the start frequency of the measurement must be ≥ 55 MHz. For measurements between 50 GHz and 67 GHz, an additional high-pass filter is required (two back-to-back Agilent V281A waveguide-to-coax adapters recommended; must be ordered separately).

PNA Family Application Options *(continued)*

Measurement applications *(continued)*

Solid black series name indicates the feature is available on that series, while gray series name with strikethrough indicates the feature is not available on that series. For example;

PNA: Available on PNA Series

~~PNA~~: Not available on PNA Series

Source phase control (Option 088)

PNA-X PNA ~~PNA-L~~

This option allows users to set calibrated, arbitrary phase differences between two signal sources. The sources can be the analyzer's internal sources or external signal generators routed through the analyzer's test set. The phase difference can be fixed, or swept between two specified phase values. Option 088 also controls the relative power level between the sources using the receiver-leveling feature. Option 088 is useful for two applications. The first is for active-load control, where the analyzer provides a precise, electronically settable impedance to the output port of a device, while gain and output power are measured. This capability can be combined with external load-pull software to create traditional load-pull power contours. The second application is to provide a pair of phase-controlled sources for differential, quadrature, or arbitrary phase-off set signals at a fixed or swept frequency. Typically in this case, another instrument, receiver, or detector would be used to measure the response of the DUT. Not available with PNA Option 200.

Integrated true-mode stimulus application (Option 460)

PNA-X PNA ~~PNA-L~~

Integrated true-mode stimulus application (iTMSA) provides mismatch-corrected true-mode (true differential mode and true common mode) stimulus and enables accurate balanced measurements under real operating conditions. iTMSA also provides balanced measurements with forward-only sweep, reverse-only sweep, and frequency or power sweep with arbitrary phase and amplitude offsets. Requires one of Options 400, 401, 417, 419 and 423.

N-port capabilities (Option 551)¹

PNA-X PNA PNA-L

Adds a multipoint analyzer mode, which enables full N-port error correction and measurement capabilities using an external test set. Only standard measurement class is available in the multipoint analyzer mode. For multipoint analysis greater than 8 ports, it is highly recommended to use PLTS software N1930B to manage the large data format files that easily grow exponentially (12 port S-parameter files have 144 S-parameter elements).

Noise figure options

Noise figure measurements using standard receivers (Option 028)

PNA-X PNA ~~PNA-L~~

This option adds firmware for high-accuracy noise figure measurements of amplifiers, frequency converters, and mixers using the analyzer's standard receivers, and utilizing Agilent's unique source-correction technique. Using an Agilent ECal module configured as an impedance tuner (N4691B/93A/94A-M0F recommended; must be ordered or supplied separately), the effects of imperfect system-source match are removed, greatly improving the accuracy of the cold-source technique. This approach surpasses the accuracy provided by the Y-factor method and other cold-source implementations. A scalar calibration choice is also available that offers less accuracy but is faster and does not require the external ECal module used as an impedance tuner. For calibration, a power meter and separate ECal module or mechanical calibration kit is required (must be ordered or supplied separately). An external preamplifier and filter(s) is required for devices with < 30 dB of excess noise (gain plus noise figure in dB) up to 20 GHz, < 40 dB up to 50 GHz, or < 45 dB up to 67 GHz. Front panel jumpers provide a convenient spot for adding a preamplifier and filter for low gain, low noise figure devices. Not available with N522xA-200 and -400.

1. When configuring N524xA as a multipoint analyzer using Option 551 and a multipoint test set, the combiner feature of Option 224 or 423 is temporarily disabled. When configured as a standalone analyzer, the combiner feature is enabled. When ordering a test set, select an appropriate interface kit. Refer to page 21 Multipoint Measurements section for more details.

PNA Family Application Options (continued)

Noise figure options (continued)

Solid black series name indicates the feature is available on that series, while gray series name with strikethrough indicates the feature is not available on that series. For example:

PNA: Available on PNA Series

~~PNA:~~ Not available on PNA Series

□ Fully-corrected noise figure measurements (Option 029)

PNA-X ~~PNA~~ ~~PNA-L~~

This option adds a low-noise receiver and firmware to the PNA-X¹ for high-accuracy noise figure measurements of amplifiers, frequency converters, and mixers, utilizing Agilent's unique source-correction technique. Using an Agilent ECal module configured as an impedance tuner for N5241/42A (3.5 mm N4691B-M0F recommended; must be ordered or supplied separately), or a built-in tuner for N5244/45/47A, the effects of imperfect system-source

match are removed, greatly improving the accuracy of the cold-source technique. This approach surpasses the accuracy provided by the Y-factor method and other cold-source implementations. A scalar calibration choice is also available that offers less accuracy but is faster, and for N5241/42A, does not require the external ECal module used as an impedance tuner. For calibration of the noise receiver, Option 029 requires a power meter or a 346 series noise source (346C or 346C-K01 recommended). For measurements of mixers and converters, a power meter is always required. The noise source and power meters are only used during calibration of the analyzer, and must be ordered or supplied separately. During the S-parameter portion of the noise calibration, a separate ECal module or mechanical calibration kit is required (also must be ordered or supplied separately). Option 029 also allows noise figure measurements using the standard receivers for high-gain (> 60 dB), narrowband devices that might otherwise overload the low-noise receiver, or for noise figure measurements up to 67 GHz on the N5247A¹.

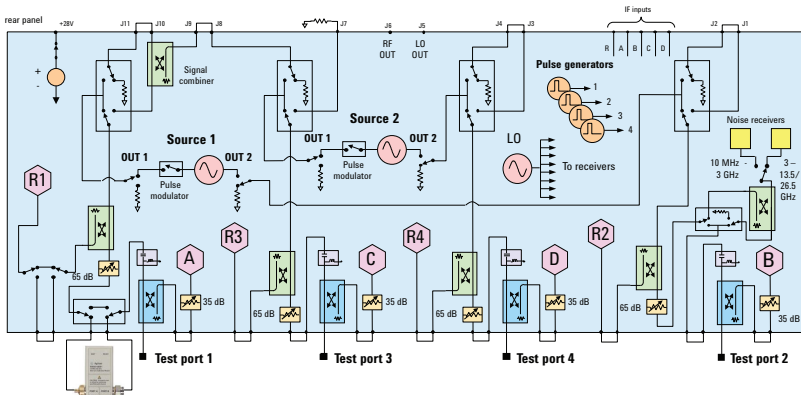

N5241/42A 4-port block diagram with noise figure option

Impedance tuner for noise figure measurements

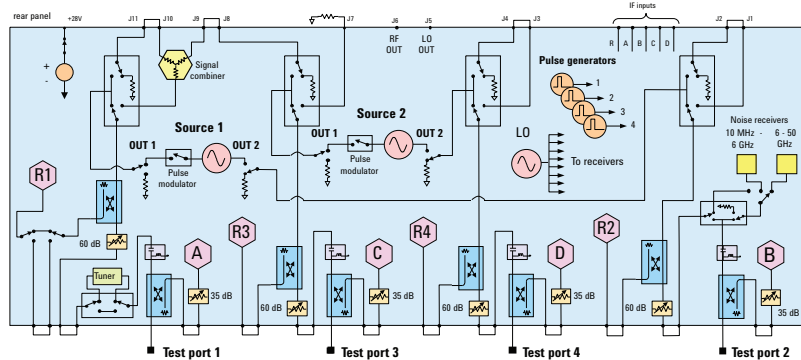

N5244/45A 4-port block diagram with noise figure option

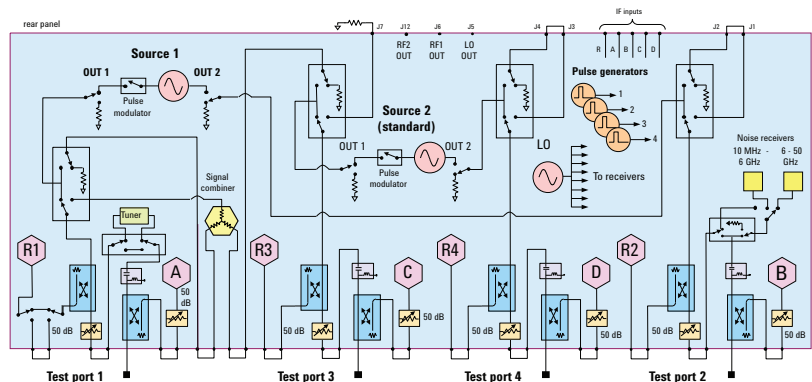

N5247A 4-port block diagram with noise figure option

1. For N5247A, the low-noise receiver works up to 50 GHz only

Noise figure options summary

Overview	Option 028	Option 029
Description	Noise figure application using standard receivers only, for all PNA / PNA-X models.	Noise figure application using standard or low-noise receivers, for all PNA-X models.
Required options	080, and 082 or 083 for measuring frequency converters. Not available with N522xA-200 and -400.	For N5241/42A, 080 and one of 219, 224, 419, 423, or H85. For N5244/45/47A, 080 and one of 224 or 423. For measuring frequency converters, requires Option 082 or 083.
Includes low-noise receivers	No	Yes ¹
Includes filters for LO-harmonic rejection	No	Yes ¹
Includes source tuner bypass switch	No	Yes
Use standard receivers for noise figure measurements ²	Yes	Yes
Vector noise calibration available using ECal as tuner	Yes	Yes
Vector noise calibration using built-in tuner	No	Yes, for N5244/45/47A
Recommended ECal for vector noise calibration	3.5 mm N4691B-M0F (N5221/22/41/42A) 2.4 mm N4693A-M0F (N5224/25/44/45A) 1.85 mm N4694A-M0F (N5227/47A)	3.5 mm N4691B-M0F (N5241/42A) Built-in for N5244/45/47A
Included tuner accessories for m-f ECal	3.5 mm N5242-20137 cable, 85052-60013 m-f adapter (N5221/22/41/42A) 2.4 mm N5245-20140 cable, 85056-60007 m-f adapter (N5224/25/44/45A) 1.85 mm N5247-20142 cable, 85058-60115 m-f adapter (N5227/47A)	3.5 mm N5242-20137 cable, 85052-60013 m-f adapter (N5241/42A) N/A for N5244/45/47A, due to built-in tuner
Recommended adapter for f-f ECal tuner (N4691B/93A/94A-00F)	3.5 mm 85052-60014 m-m adapter (N5221/22/41/42A) 2.4 mm 85056-60005 m-m adapter (N5224/25/44/45A) 1.85 mm 85058-60113 m-m adapter (N5227/47A)	3.5 mm 85052-60014 m-m adapter (N5241/42A) N/A for N5244/45/47A, due to built-in tuner
Scalar noise calibration available	Yes	Yes
S-parameter, conversion gain/loss measurements		
Max freq (GHz)	13.5/26.5/43.5/50/67	13.5/26.5/43.5/50/67
NF measurements, amplifiers		
Max frequency, using low-noise receivers (GHz)	N/A	13.5/26.5/43.5/50
Max frequency, using standard receivers (GHz) ²	13.5/26.5/43.5/50/67	13.5/26.5/43.5/50/67
Calibration accessories for low-noise receivers	N/A	Cal kit or ECal, 346C or 346C-K01 noise source or power meter
Calibration accessories for standard receivers	Cal kit or ECal, power meter	Cal kit or ECal, power meter
NF measurements, converters		
Max input frequency (GHz)	13.5/26.5/43.5/50/67	13.5/26.5/43/5/50/67
Max output frequency, using low-noise receivers (GHz)	N/A	13.5/26.5/43/5/50
Max output frequency, using standard receivers (GHz) ²	13.5/26.5/43.5/50/67	13.5/26.5/43.5/50/67
Calibration accessories for low-noise receivers	N/A	Cal kit or ECal, power meter, 346C or 346C-K01 noise source (optional)
Calibration accessories for standard receivers	Cal kit or ECal, power meter	Cal kit or ECal, power meter

1. For N5247A, the low-noise receiver works up to 50 GHz only.

2. External preamplifier and filter(s) required if DUT excess noise (gain plus noise figure) is < 30 dB up to 20 GHz, < 40 dB up to 50 GHz, or < 45 dB up to 67 GHz.

PNA Family Application Options *(continued)*

Pulse, antenna, mm-wave

Solid black series name indicates the feature is available on that series, while gray series name with strikethrough indicates the feature is not available on that series. For example;

PNA: Available on PNA Series

~~PNA:~~ Not available on PNA Series

Pulsed-RF measurements (Option 008)

PNA-X **PNA** ~~PNA~~

This option adds narrowband pulse detection mode and extends the pulsed-RF measurement capability to narrower pulse widths below the limit for the standard wideband detection mode. The PNA-X and PNA are complete pulsed-RF solutions with built in pulse generators and modulators, so external test sets and pulse generators are not required. With narrowband detection mode, Option 008 sets the coefficient of the analyzer's digital-IF filters to null out unwanted spectral components, enables the internal receiver IF gates, controls internal pulse generators (Option 025), internal pulse modulators (Option 021 and/or 022), and external pulse modulators, and performs optimization for measurement sensitivity. Option 008 also includes conventional pulsed-RF measurement software (Option H08). Option 025 is required. Option 021 is recommended for forward-only pulsed-RF measurements. Option 021 and 022 are recommended for bi-directional pulsed-RF measurements. The N1966A pulse I/O adapter is recommended if using external pulse generators and/or external pulse modulators

Add IF inputs for antenna and millimeter-wave (Option 020)

PNA-X **PNA** ~~PNA~~

This option enables external IF inputs on the rear panel of the analyzer for applications such as antenna and millimeter-wave test.

Add pulse modulator to internal first source (Option 021)

PNA-X **PNA** ~~PNA~~

This option enables the internal pulse modulator on Source1 Out1. Control of the modulator can also be done via pin 8 of the Pulse I/O D-sub connector on the rear panel of the analyzer using an external pulse generator, or by using one of the internal pulse generators (Option 025). The N1966A pulse I/O adapter is recommended if using an external pulse generator.

Add pulse modulator to internal second source (Option 022)

PNA-X **PNA** ~~PNA~~

This option enables the internal pulse modulator on Source2 Out1. Control of the modulator can also be done via pin 8 of the Pulse I/O D-sub connector on the rear panel of the analyzer using an external pulse generator, or by using one of the internal pulse generators (Option 025). The N1966A pulse I/O adapter is recommended if using an external pulse generator. Option 224 or 400 is required for PNA-X, and one of Option 400, 401, 417, or 419 is required for PNA.

Add four internal pulse generators (Option 025)

PNA-X **PNA** ~~PNA~~

This option enables four internal pulse generators. These pulse generators can be used to control the internal pulse modulators and internal receiver IF gates, and are also available on pins 10 through 13 of the Pulse I/O D-sub connector on the rear panel of the analyzer to control external modulators and/or gates. The N1966A pulse I/O adapter is recommended if using external pulse modulators.

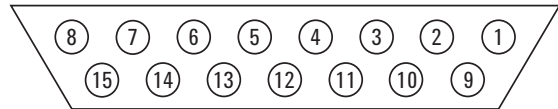

Pulse I/O D-sub connector (DB-15 female)

Fast CW Sweep (Option 118)

PNA-X **PNA** ~~PNA~~

This option uses FIFO (first-in first-out) to allow external point-trigger acquisition of 400,000 data points per second on five measurement receivers. When enabled, there is no display update, no background computation, or other interference from the vector network analyzer application. All the data gathered is placed into a 500 million points FIFO buffer. While the data is going into FIFO it can be read from the FIFO buffer.

Nonlinear vector network analysis

Please refer to 5989-8575EN Nonlinear Vector Network Analyzer brochure for more information.

PNA Family Application Options *(continued)*

Accessories

Solid black series name indicates the feature is available on that series, while gray series name with strikethrough indicates the feature is not available on that series. For example;

PNA: Available on PNA Series

~~PNA:~~ Not available on PNA Series

- **Rack mount kit without handles (Option 1CM)**

PNA-X **PNA** ~~PNA-L~~

Adds a rack mount (ICM042A) and rail kit (E3663AC) for use without handles.

- **Rack mount kit with handles (Option 1CP)**

PNA-X **PNA** ~~PNA-L~~

Adds handles (5063-9230), a rack mount (5063-9237) and rail kit (E3663AC) for use with handles.

- **Pulse I/O adapter (N1966A)**

PNA-X **PNA** ~~PNA-L~~

An adapter for connecting between the Pulse I/O connector on the rear panel of the analyzer and the coaxial inputs and outputs of external pulse generators and external pulse modulators. Coaxial connectors are SMB-male. The PULSE IN connectors are for controlling the analyzer's internal IF gates, which are enabled with Option 008 and used with narrowband detection. The PULSE OUT connectors are from the four internal pulse generators, which are enabled with Option 025. The PULSE SYNC IN connector is used to synchronize the internal pulse generators with an external timing pulse. The RF PULSE MOD IN connector controls the internal pulse modulator(s) which are enabled with Options 021 and 022.

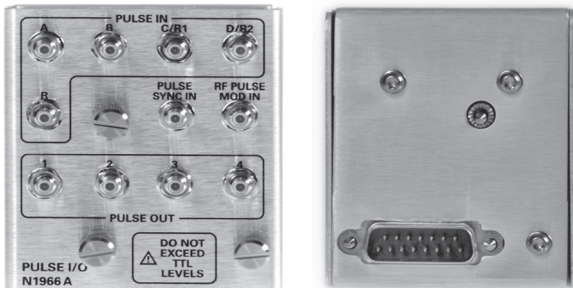

Pulse I/O adapter (N1966A) simplifies connections

- **Comb Generators**

U9391C 10 MHz to 26.5 GHz

U9391F 10 MHz to 50 GHz

U9391G 10 MHz to 67 GHz

PNA-X **PNA** ~~PNA-L~~

The U9391C/F/G provides precision phase calibration, traceable to the National Institute of Standards and Technology (NIST) standard. It is used for nonlinear measurements with the PNA-X nonlinear vector network analyzer (NVNA). NVNA requires two comb generators, one is connected during measurements and another is used only during calibration. A comb generator is also used to characterize the VNA receivers for delay measurements of frequency converters using PNA-X or PNA with Option 083.



Comb generator enables vector-corrected measurements in fundamental/harmonic frequencies

- **N1930B Physical Layer Test System Software (PLTS) version 2012**

PNA-X **PNA** ~~PNA-L~~

The Physical Layer Test System (PLTS) version 2012 software is a powerful signal integrity tool for today's high-speed digital designers. The PLTS software platform has become an industry standard for calibration, measurement and analysis of linear passive interconnects such as cables, connectors, backplanes and printed circuit boards. Utilizing either a Vector Network Analyzer (VNA) or Time Domain Reflectometer (TDR), fast and accurate measurements can be obtained without in-depth knowledge of microwave measurement techniques.

Key features and specifications

- Advanced test suite wizard with calibration and de-embedding for enhanced automation
- Passivity and causality checker for validating simulation engine compatibility
- Advanced automatic fixture removal for non-symmetric fixture applications
- Save/load formula to existing view for easy customization and test development

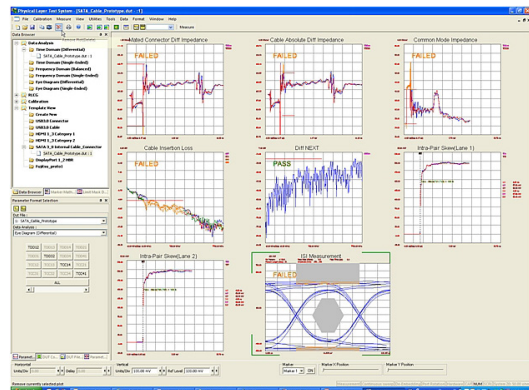

PNA Family Network Analyzer Upgrade Kits

Frequency, test ports, test set and power configurations

Upgrade kits are available to add options after initial purchase. To upgrade the PNA-X/PNA/PNA-L, order the corresponding item number. The model and serial numbers of the instrument to be retrofitted are required as part of the order.

Description	Required Option	For PNA-X Series	For PNA Series	For PNA-L Series	User Installable
Frequency upgrade¹					
Extend analyzer's frequency range to 13.5 GHz	N5239A	n/a	n/a	N5239AU-613	No
Extend analyzer's frequency range to 20 GHz	N5239A or N5231A	n/a	n/a	N5239AU/31AU-620	No
Extend analyzer's frequency range to 26.5 GHz	N5241A or N5221A	N5241AU-960	N5221AU-626	n/a	No
Extend analyzer's frequency range to 50 GHz	N5244A, N5224A or N5234A	N5244AU-990	N5224AU-650	N5234AU-650	No
Test ports					
Expand 2-ports, single source without configurable test set to 4-ports	N522xA-200	n/a	N522xAU-600	n/a	No
Expand 2-ports, single source with configurable test set to 4-ports	N524xA-200 or N522xA-201	N524xAU-940	N522xAU-601	n/a	No
Expand 2-ports, single source with configurable test set and extended power range to 4-ports	N522xA-217	n/a	N522xAU-617	n/a	No
Expand 2-ports, single source with configurable test set, extended power range and bias-tees to 4-ports	N524xA-219 or N522xA-219	N524xAU-942	N522xAU-619	n/a	No
Expand 2-ports, internal second source with configurable test set, extended power range, bias-tees, combiner and mechanical switches to 4-ports	N524xA-224	N524xAU-944	n/a	n/a	No
Test set and power configuration					
Add configurable test set, 2-ports	N522xA-200	n/a	N522xAU-201	n/a	No
Add configurable test set and source attenuators, 2-ports	N523xA-200	n/a	n/a	N523xAU-216	No
Add extended power range, 2-ports ²	N522xA-201	n/a	N522xAU-217	n/a	No
Add bias-tees, 2-ports ²	N522xA-217	n/a	N522xAU-219	n/a	No
Add extended power range and bias-tees, 2-ports	N524xA-200 or N5227A-201	N524xAU-921	N5227AU-217/219	n/a	No
Add internal 2nd source, combiner and mechanical switches, 2-ports	N524xA-219 or N522xA-219	N524xAU-922	n/a	n/a	No
Add high power configurable, 2-ports	N524xA-219 or 224	N524xAU-H85	n/a	n/a	No
Add configurable test set, 4-ports	N522xA-400	n/a	N522xAU-401	n/a	No
Add configurable test set and source attenuators, 4-ports	N523xA-400	n/a	n/a	N523xAU-416	No
Add extended power range, 4-ports ²	N522xA-401	n/a	N522xAU-417	n/a	No
Add bias-tees, 4-ports ²	N522xA-417	n/a	N522xAU-419	n/a	No
Add extended power range and bias-tees, 4-ports	N524xA-400 or N5227A-401	N524xAU-926	N5227AU-417/419	n/a	No
Add internal 2nd source, combiner and mechanical switches, 4-ports	N524xA-419 or N522xA-419	N524xAU-927	n/a	n/a	No
Add high power configurable, 4-ports	N524xA-419 or 423	N524xAU-H85	n/a	n/a	No

1. Frequency upgrade options from 8.5/13.5/20/26.5 GHz to 43.5/50 GHz and 43.5/50 GHz to 67 GHz are not available. Trade-in is recommended.

2. Not available on N5227A.

PNA Family Network Analyzer Upgrade Kits (continued)

Application options

Upgrade kits are available to add options after initial purchase. To upgrade the PNA-X/PNA/PNA-L, order the corresponding item number. The model and serial numbers of the instrument to be retrofitted are required as part of the order.

Description	Required Option	For PNA-X Series	For PNA Series	For PNA-L Series	User Installable
Measurement applications					
Time-domain measurements		N524xAU-010	N522xAU-010	N523xAU-010	Yes
Noise figure measurements using standard receivers	Option 080 ^{1,2}	N524xAU-028	N522xAU-028	n/a	Yes
Fully-corrected noise figure measurements for PNA-X, 2-ports	Option 080 and for N5241/42A, one of Options 219, 224 or H85 ¹ . For N5244/45/47A, 080 and 224	N524xAU-924 ³	n/a	n/a	No
Fully-corrected noise figure measurements for PNA-X, 4-ports	Option 080 and for N5241/42A, one of Options 419, 423 or H85 ¹ . For N5244/45/47A, 080 and 423	N524xAU-929 ³	n/a	n/a	No
Frequency offset		N524xAU-080	N522xAU-080	N523xAU-080	Yes
Scalar-calibrated converter measurements	Option 080	N524xAU-082	N522xAU-082	N523xAU-082	Yes
Vector- and scalar-calibrated converter measurements	Option 080	N524xAU-083	N522xAU-083	n/a	Yes
Embedded LO measurements	Option 082 or 083	N524xAU-084	N522xAU-084	n/a	Yes
Gain compression application	See Footnote 1	N524xAU-086	N522xAU-086	n/a	Yes
Intermodulation distortion application	Option 080 ^{1,4}	N524xAU-087	N522xAU-087	n/a	Yes
Source phase control	See Footnote 5	N524xAU-088	N522xAU-088	n/a	Yes
Integrated true-mode stimulus application	Option 400, 401, 417, 419, or 423	N524xAU-460	N522xAU-460	n/a	Yes
N-port capabilities	See Footnote 6	N524xAU-551	N522xAU-551	N523xAU-551	Yes
Pulse, antenna, mm-wave					
Pulsed-RF measurements	Option 025 ¹	N524xAU-008	N522xAU-008	n/a	Yes
Add IF inputs		N524xAU-020	N522xAU-020	n/a	Yes
Add pulse modulator to internal 1st source		N524xAU-021	N522xAU-021	n/a	Yes
Add pulse modulator to internal 2nd source	Option 224, 400, 401, 417, 419, or 423	N524xAU-022	N522xAU-022	n/a	Yes
Add four internal pulse generators		N524xAU-425	N522xAU-425	n/a	Yes
Fast CW sweep		N524xAU-118	N522xAU-118	n/a	Yes
Nonlinear network vector analysis					
Nonlinear component characterization	Options 419 and 080, or 400, H85 and 080	N524xAU-510	n/a	n/a	Yes
Nonlinear X-parameters	Options 423 and 510	N524xAU-514	n/a	n/a	Yes
Nonlinear pulse envelope domain	Requires Options 021, 025 and either one of 510 or 514	N524xAU-518	n/a	n/a	Yes
Arbitrary load-impedance X-parameters	Option 514	N524xAU-520	n/a	n/a	Yes
Calibration software					
Perpetual license for built-in performance test software for Agilent inclusive calibration		N524xAU-897	N522xAU-897	N523xAU-897	Yes
Perpetual license for built-in performance test software for standard compliant calibration		N524xAU-898	N522xAU-898	N523xAU-898	Yes

1. For measuring frequency converters, Option 082 or 083 is required.

2. Requires configurable test set for signal conditioning of noise figure measurements using standard receivers. Therefore it is not available with N522xA-200 and -400.

3. Upgrading N5244A units with noise figure hardware requires serial-number prefixes of 5204 or higher, and upgrading N5245A units requires serial-number prefixes of 5205 or higher. For these two models, units with lower serial-number prefixes can be traded in for credit towards a new unit with the noise figure hardware.

4. Two-tone signal must be routed to R1 receiver after an external combiner; therefore it is not available with N522xA-200 and 400.

5. When used with an external signal generator, configurable test set is required to access a receiver. Therefore it is not available with N522xA-200.

6. To connect a multiport test set, configurable test set is required. Therefore it is not available with N522xA-200/400, and N523xA-200/400.

PNA Family Network Analyzer Upgrade Kits

Upgrade paths

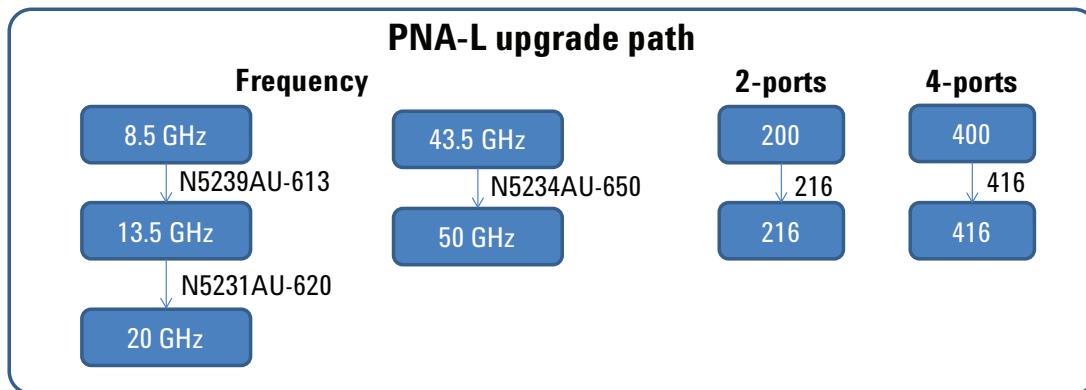
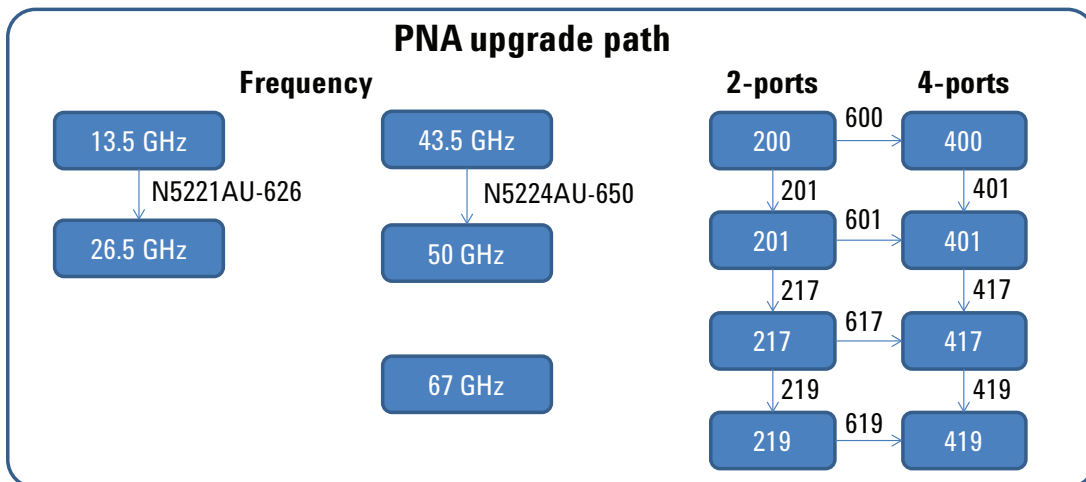
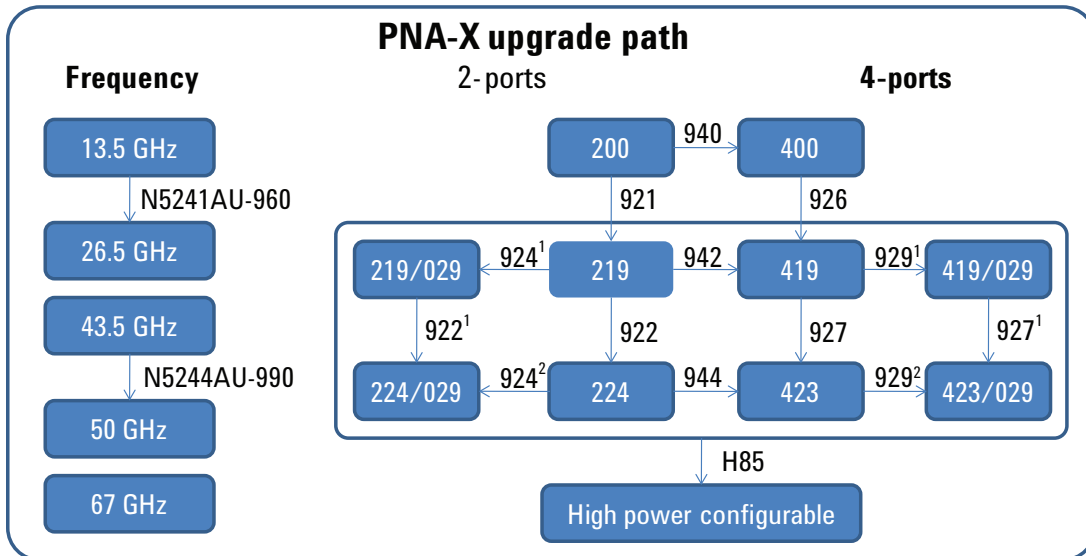

1. This upgrade path only available on N5241/42A.
2. Upgrading N5244A units with noise figure hardware requires serial-number prefixes of 5204 or higher, and upgrading N5245A units requires serial-number prefixes of 5205 or higher. For these two models, units with lower serial-number prefixes can be traded in for credit towards a new unit with the noise figure hardware.

Applications

Material measurements

- **85070E** High-Temperature Dielectric Probe Kit
The 85070E enables measurements of the dielectric properties of materials quickly and conveniently. Measurements made with this probe are nondestructive and require no sample preparation. The dielectric probe is well suited for measurements of liquid, semisolid and flat solid materials. Measurement results can be viewed in a variety of formats (ϵ'_r , ϵ''_r , $\tan \delta$ or Cole-Cole). The supplied software can be run in the PNA analyzer or on a PC.
- **85071E** Materials Measurement Software
The 85071E materials measurement software calculates the permittivity and permeability of material samples placed in a coaxial airline or a rectangular waveguide. The measurement technique works well for solid materials that can be machined to fit precisely inside a transmission line. Measurement results can be viewed in a variety of formats (ϵ'_r , ϵ_r , μ'_r , μ''_r , $\tan \delta$, or Cole-Cole μ). The software can be run in the PNA analyzer or on a PC.

Signal integrity measurements

- **N1930B** Physical Layer Test System (PLTS) Software
The PLTS software platform has become an industry standard for calibration, measurement and analysis of linear passive interconnects such as cables, connectors, backplanes and printed circuit boards. Utilizing either a vector network analyzer (VNA) or a time domain reflectometer (TDR), fast and accurate measurements can be obtained without in-depth knowledge of microwave measurement techniques. Refer to www.agilent.com/find/plts or the technical overview, literature number 5989-6841EN for more details.

Multiport measurements

The multiport test sets are designed to work with the PNA Family of network analyzers and provide network analysis with a single set of connections for devices that have multiple ports. The test sets are configured in a variety of ways, for extension or switching, electro-mechanical or solid-state switches, number of test ports, frequency range, and 2- or 4-ports depending on your analyzer.

Test set types—extension and switching test sets

Switching test sets provide an economical solution for RF applications. This test set is connected to the test ports of the VNA, and group of test ports share the directional couplers and receivers in the VNA. An extension test set is connected to the sources and test receivers through configurable test set of the VNA. It features a directional coupler for every test port and all switching occurs behind the directional couplers, which provides the ultimate in flexibility, stability, and performance for RF and microwave applications.

Switch types – electro-mechanical and solid-state switches

The electro-mechanical switches have less insertion loss, higher power handling, and linear responses. Thus it is recommended for testing active devices, high-power devices, and devices that require wide dynamic range. However, they have limited switching life (mostly 5 million cycles) and long setting time. On the other hand, the solid-state switches have unlimited switching life, very fast switching speed and excellent repeatability thus they are often used for high volume passive device tests, and S-parameter measurements of passive components can be performed.

Test set model number

Multiport test set model numbers represent the test set types, note the numbering scheme below.

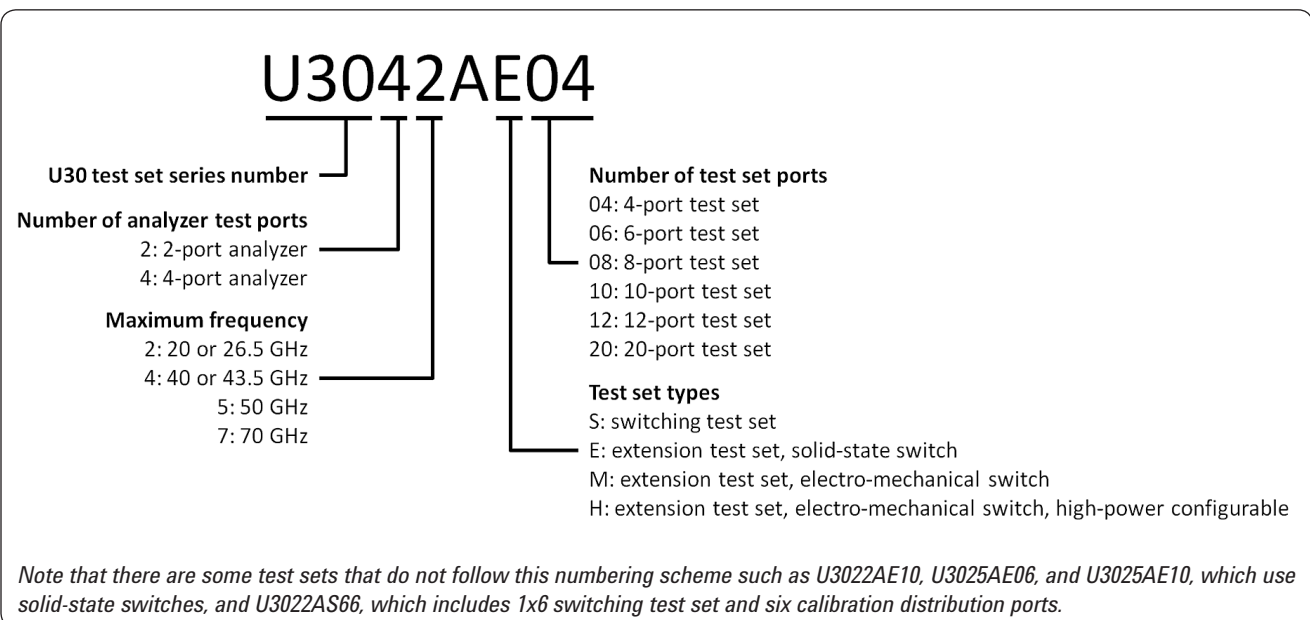

Test set options

One of the following test set options must be selected.

Standard configuration (Option 700)

The standard configuration is the basic test set configuration, which does not include signal conditioning devices such as amplifiers.

Add amplifiers for improved dynamic range (Option 001)

Option 001 adds an amplifier between each test port coupler and the receiver switch to improved system dynamic range. It is primarily offered for the test set with solid-state switches to compensate for the insertion loss.

Add amplifiers and bias-tees (Option 002)

Option 002 adds an amplifier between each test port coupler and the receiver switch to improved system dynamic range and bias-tees for all test ports on the test set as well as the analyzer. It is primarily offered for the test set with solid-state switches to compensate for the insertion loss.

Interface kits

The interface kit includes a set of semi-rigid RF jumper cables and two pairs of rear locking feet that connect and lock the analyzer and the test set together. When ordering a multiport test set, the analyzer that is used with the test set must be specified to add one of the following interface kits. The availability depends on the test set model. There are following three interface kit models based on the jumper connector layouts on the test set. Therefore, only one interface kit model ("PX", "PN", or "PL") is available on each test set. Each interface kit model has one digit suffix indicating the connector type; 1 for 1.85 mm, 2 for 2.4 mm and 3 for 3.5 mm (or SMA).

- U3021PXx** Interface kit for test set with jumper connectors to align with N524xA PNA-X and N522xA PNA
- U3021PNx** Interface kit for test set with jumper connectors to align with E836xB/C PNA and N5230A/C-x25 2-port PNA-L
- Option 261** For use with E8361A/C 2-port PNA
- Option 262** For use with E8362B/C 2-port PNA or N5230A/C-225 2-port PNA-L
- Option 263** For use with E8363B/3C/4B/4C 2-port PNA or N5230A/C-425/525 2-port PNA-L
- Option 430** For use with N5230A/C-245/246 4-port PNA-L
- Option 242** For use with N5241A/2A-2xx 2-port PNA-X or N5221A/2A-2xx 2-port PNA
- Option 442** For use with N5241A/2A-400 4-port PNA-X or N5221A/2A-4xx 4-port PNA
- Option 245** For use with N5244A/5A-200 2-port PNA-X or N5224A/5A-2xx 2-port PNA
- Option 445** For use with N5244A/5A-400 4-port PNA-X or N5224A/5A-4xx 4-port PNA
- Option 247** For use with N5247A-200 2-port PNA-X or N5227A-2xx 2-port PNA
- Option 447** For use with N5247A-400 4-port PNA-X or N5227A-4xx 4-port PNA

When ordering an additional cable set, a spare cable or rear locking feet, refer to the multiport test set user's guide or go to: www.agilent.com/find/multiport

Millimeter-wave measurements

Single sweep solution to 110 GHz

The 67 GHz PNA and PNA-X network analyzers allow extending the maximum frequency to 110 GHz with a 1.0 mm coaxial connector, enabling 10 MHz to 110 GHz single sweep measurements using a millimeter-wave controller and frequency extenders with built-in combiner.

The 10 MHz to 110 GHz broadband millimeter-wave system provides high performance and capabilities including power control, 4-port true-differential, and frequency converter measurements. It is configured with an N5227A PNA with Option 201 (2-ports) or Option 401 (4-ports), or N5247A with Option 200 (2-ports) or Option 400 (4-ports), Option 020 IF access, an N5261A 2-port or an N5262A 4-port millimeter-wave test set controller with 1.85 mm coaxial cables (Option 112 for N5261A, Option 114 for N5262A) and RF/LO/IF/DC cables sets (to select the cable length and quantities), and one (for 2-ports) or two (for 4-ports) each of right and left frequency extenders with required attenuators and bias-tee configurations.

Waveguide banded solutions to 1.05 THz

The waveguide banded millimeter-wave solution covers waveguide bands from 50 GHz to 1.05 THz. A 2- or 4-port PNA or PNA-X in conjunction with N5261A (for 2-port) or N5262A (for 4-port) configures for the most complete millimeter wave solution. It is configured with a PNA Series with Option 020 IF access, configurable test set (Option 201 or 401), and frequency offset mode (Option 080), or PNA-X Series with 2-port (Option 200) or 4-port (Option 400) and IF access (Option 020). For the millimeter-wave test controller, appropriate RF cable option and RF/LO/IF/DC cable set option for frequency extenders must be selected for the analyzer's connector type, number of test ports, and lengths. Add appropriate frequency extenders with required quantity for the measurements.

For complete list of millimeter-wave products and options, and ordering instructions, please refer to 5989-7620EN Millimeter-wave Network Analyzers Technical Overview.

Measurement Accessories

A complete list of RF and microwave test accessories is available on our Web site:

www.agilent.com/find/accessories

Accessories are available in these connector types: 50 ohm Type-N, 3.5 mm, 7 mm, 2.4 mm, 2.92 mm, 1.85 mm, 1.0 mm, and waveguide. Test port cables and a calibration kit should be added for a complete measurement system. A verification kit is used to verify corrected system performance.

Cables and adapter sets

Agilent offers cables in the following types:

- single cables in semi-rigid and flexible
- cable sets in semi-rigid and flexible

There are also adapter sets available that protect the test port and convert the port to the desired connector interface. These kits contain:

- one male adapter
- one female adapter

To attain the best mechanical rigidity for device connection, use a single cable and the appropriate special adapter set. To attain the greatest flexibility for device connection, use a cable set.

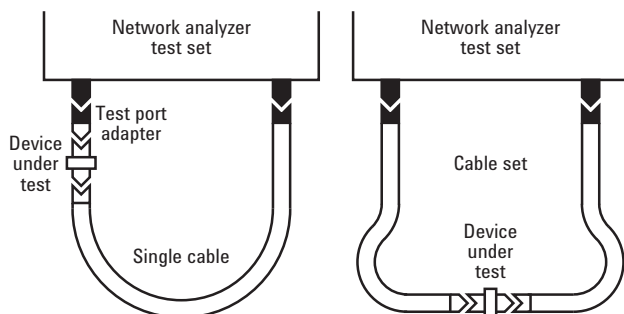

Calibration kits

Coaxial measurements

Mechanical calibration kits include standards, such as opens, shorts and loads, which are measured by the network analyzer for increased measurement accuracy.

Electronic calibration (ECal) kits replace mechanical calibration standards with one solid-state calibration module that is controlled by the network analyzer via USB, to present many different impedances to the test ports. A full two-port calibration can be performed quickly with a single connection. This technique reduces operator errors and connector wear and abrasion.

Choose a calibration kit for each connector type to be used.

Economy, includes:

- open standards (male and female)
- short standards (male and female)
- fixed-termination standards (male and female)

Standard, includes the devices in the economy kit and adds:

- sliding load standards (male and female) or a series of offset shorts

Precision, includes the devices in the economy kit and adds:

- 50 ohm airline(s) for TRL calibration
- TRL adapters

Waveguide measurements

For waveguide measurements, Agilent offers mechanical calibration kits that include:

- waveguide-to-coax adapters (X, P, K, R, Q, U, V)
- precision waveguide section
- flush short circuit
- fixed terminations
- straight section

For devices with 1.0 mm connectors

Mechanical calibration/verification kit

- **85059A** DC to 110 GHz precision calibration/verification kit.
Includes:
 - 85059-60003 1.00 mm (m) short 2.450 mm
 - 85059-60007 1.00 mm (f) short 2.450 mm
 - 85059-60004 1.00 mm (m) short 3.000 mm
 - 85059-60008 1.00 mm (f) short 3.000 mm
 - 85059-60002 1.00 mm (m) short 1.825 mm
 - 85059-60006 1.00 mm (f) short 1.825 mm
 - 85059-60001 1.00 mm (m) short 1.300 mm
 - 85059-60005 1.00 mm (f) short 1.300 mm
 - 85059-60009 1.00 mm male open
 - 85059-60010 1.00 mm female open
 - 85059-60019 1.00 mm male load
 - 85059-60020 1.00 mm female load
 - 85059-60021 1.00 mm lossy delay line
 - 11920-60001 1.00 mm (m) to 1.00 mm (m) adapter
 - 11920-60002 1.00 mm (f) to 1.00 mm (f) adapter
 - 11920-60003 1.00 mm (m) to 1.00 mm (f) adapter
 - 11500-60001 1.00 mm (f) to 1.00 mm (f) 8.8 cm cable
 - 85059-60016 1.00 mm mismatch thru adapter for verification
 - 85059-60017 1.00 mm matched thru adapter for verification
- 8710-2079 6 mm, 4 in-lb torque wrench
- 8710-2156 6 mm open end wrench

Cables

- **11500I** 1.0 mm (f-f) test port cable (8.8 cm)
- **11500J** 1.0 mm (m-f) test port cable (16.0 cm)¹
- **11500K** 1.0 mm (m-f) test port cable (20.0 cm)¹
- **11500L** 1.0 mm (m-f) test port cable (24.0 cm)¹

Adapter set

- **V281C** 1.0 mm(f) to V-band waveguide adapter
- **V281D** 1.0 mm (m) to V-band waveguide adapter
- **W281C** 1.0 mm (f) to W-band waveguide adapter
- **W281D** 1.0 mm (m) to W-band waveguide adapter
- **11920A** 1.0 mm (m) to 1.0 mm (m) adapter
- **11920B** 1.0 mm (f) to 1.0 mm (f) adapter
- **11920C** 1.0 mm (m) to 1.0 mm (f) adapter
- **11921A** 1.0 mm (m) to 1.85 mm (m) adapter
- **11921B** 1.0 mm (f) to 1.85 mm (f) adapter
- **11921C** 1.0 mm (m) to 1.85 mm (f) adapter
- **11921D** 1.0 mm (f) to 1.85 mm (m) adapter
- **11922A** 1.0 mm (m) to 2.4 mm (m) adapter
- **11922B** 1.0 mm (f) to 2.4 mm (f) adapter
- **11922C** 1.0 mm (m) to 2.4 mm (f) adapter
- **11922D** 1.0 mm (f) to 2.4 mm (m) adapter
- **11923A** 1.0 mm (f) connector launch assembly

1. For on-wafer applications, two 11500J/K/L cables are required; one cable for each test port.
2. Special rugged female connector specifically for connecting to the network analyzer test port, but does not mate with a standard male connector.

For devices with 1.85 mm connectors

Mechanical calibration kits

- **85058B** standard: DC to 67 GHz.
Includes:
 - 85058-60101 1.85 mm (m) short 5.4 mm
 - 85058-60102 1.85 mm (m) short 6.3 mm
 - 85058-60103 1.85 mm (m) short 7.12 mm
 - 85058-60104 1.85 mm (m) short 7.6 mm
 - 85058-60105 1.85 mm (f) short 5.4 mm
 - 85058-60106 1.85 mm (f) short 6.3 mm
 - 85058-60107 1.85 mm (f) short 7.12 mm
 - 85058-60108 1.85 mm (f) short 7.6 mm
 - 85058-60109 1.85 mm male open
 - 85058-60110 1.85 mm female open
 - 85058-60111 1.85 mm male load
 - 85058-60112 1.85 mm female load
 - 85058-60113 1.85 mm (m) to 1.85 mm (m) adapter
 - 85058-60114 1.85 mm (f) to 1.85 mm (f) adapter
 - 85058-60115 1.85 mm (m) to 1.85 mm (f) adapter
- **85058E** economy: DC to 67 GHz.
Includes:
 - 85058-60101 1.85 mm (m) short 5.4 mm
 - 85058-60105 1.85 mm (f) short 5.4 mm
 - 85058-60109 1.85 mm male open
 - 85058-60110 1.85 mm female open
 - 85058-60123 1.85 mm male load
 - 85058-60124 1.85 mm female load
 - 85058-60113 1.85 mm (m) to 1.85 mm (m) adapter
 - 85058-60114 1.85 mm (f) to 1.85 mm (f) adapter
 - 85058-60115 1.85 mm (m) to 1.85 mm (f) adapter

Electronic calibration kits

- **N4694A** Microwave ECal: 10 MHz to 67 GHz, 2-ports.
Includes:
 - Option M0F** module with:
 - N4694-60001 1.85 mm (f) to 1.85 mm (m) ECal module
 - Option 00M** module with:
 - N4694-60002 1.85 mm (m) to 1.85 mm (m) ECal module
 - Option 00F** module with:
 - N4694-60003 1.85 mm (f) to 1.85 mm (f) ECal module
 - Option 00A** adds:
 - 85058-60113 1.85 mm (m) to 1.85 mm (m) adapter
 - 85058-60114 1.85 mm (f) to 1.85 mm (f) adapter

Cables

- **N4697E²** Single, flexible: 1.85 mm (f) to 1.85 mm (f), 96.5 cm, 38 inches
- **N4697F²** Set, flexible:
 - One 1.85 mm (f) to 1.85 mm (f) cable, 62.2 cm, 24.5 inches, p/n N4697-60100
 - One 1.85 mm (f) to 1.85 mm (m) cable, 62.2 cm, 24.5 inches, p/n N4697-60200
- **N4421B-K67** Single, flexible: 1.85 mm (f) to 1.85 mm (m), 91.4 cm, 36 inches

Adapter set

- **85130H²** 1.85 mm to 1.85 mm

For devices with 2.4 mm connectors

Mechanical calibration kits

- **85056A** standard: DC to 50 GHz.
Includes:
 - 00901-60003 2.4 mm (m) fixed broadband load
 - 00902-60004 2.4 mm (f) fixed broadband load
 - 00915-60003 2.4 mm (m) sliding load
 - 00915-60004 2.4 mm (f) sliding load
 - 85056-60005 2.4 mm (m) to 2.4 mm (m) adapter
 - 85056-60006 2.4 mm (f) to 2.4 mm (f) adapter
 - 85056-60007 2.4 mm (m) to 2.4 mm (f) adapter
 - 85056-60020 2.4 mm (m) short
 - 85056-60021 2.4 mm (f) short
 - 85056-60022 2.4 mm (m) open
 - 85056-60023 2.4 mm (f) open

- **85056D** economy: DC to 50 GHz.
Includes:
 - 00901-60003 2.4 mm (m) fixed broadband load
 - 00902-60004 2.4 mm (f) fixed broadband load
 - 85056-60005 2.4 mm (m) to 2.4 mm (m) adapter
 - 85056-60006 2.4 mm (f) to 2.4 mm (f) adapter
 - 85056-60007 2.4 mm (m) to 2.4 mm (f) adapter
 - 85056-60020 2.4 mm (m) short
 - 85056-60021 2.4 mm (f) short
 - 85056-60022 2.4 mm (m) open
 - 85056-60023 2.4 mm (f) open

Electronic calibration kits

- **N4693A** Microwave ECal: 10 MHz to 50 GHz, 2-ports.
Includes:
 - Option M0F** module with:
 - N4693-60001 2.4 mm (f) to 2.4 mm (m) ECal module
 - Option 00M** module with:
 - N4693-60002 2.4 mm (m) to 2.4 mm (m) ECal module
 - Option 00F** module with:
 - N4693-60003 2.4 mm (f) to 2.4 mm (f) ECal module
 - Option 00A** adds:
 - 85056-60005 2.4 mm (m) to 2.4 mm (m) adapter
 - 85056-60006 2.4 mm (f) to 2.4 mm (f) adapter

Cables

Note: Agilent offers the following 2.4 mm test port cables. Adapters will be necessary when using these cables for 2.92 mm measurements.

- **85133C**¹ single, semi-rigid: 2.4 mm (f) to PSC-2.4 mm (f), 81 cm, 32 inches
- **85133D**¹ set, semi-rigid:
 - One 2.4 mm (f) to 2.4 mm (m), 53 cm, 21 inches, p/n 85133-60001
 - One 2.4 mm (f) to 2.4 mm (f), 53 cm, 21 inches, p/n 85133-60002
- **85133E**¹ single, flexible: 2.4 mm (f) to PSC-2.4 mm (f), 97 cm, 38 inches
- **85133F**¹ set, flexible:
 - One 2.4 mm (f) to 2.4 mm (f), 63 cm, 25 inches, p/n 85133-60016
 - One 2.4 mm (f) to 2.4 mm (m), 63 cm, 25 inches, p/n 85133-60017
- **85133H**¹ Single, flexible: 2.4 mm (f) to 2.4 mm (m), 63 cm, 25 inches
- **N4421AK20** Single, flexible: 2.4 mm (f) to 2.4 mm (m), 91.4 cm, 36 inches

1. Special rugged female connector specifically for connecting to the network analyzer test port, but does not mate with a standard male connector.
2. Special rugged female connector specifically for connecting to the network analyzers NMD 2.4 mm test port, but does not mate with standard 2.4 mm male connector

Adapter set

- **85130F** 2.4 mm¹ to 3.5 mm
- **85130F** 2.5 mm¹ to 3.5 mm
- **85130G** 2.4 mm¹ to 2.4 mm

For devices with K connectors (2.92 mm)

Mechanical calibration kits

- **85056KE01** DC to 40 GHz
For use with user supplied 2.9 mm test port cables. 2.92 mm (K connector) calibration kit with fixed and sliding loads. The Agilent 85056KE01 calibration kit is an ordering convenience to allow the pass through ordering from Agilent Technologies, Inc. for the Maury 8770C47 calibration kit.

- **85056KE02** DC to 40 GHz
For use with user supplied 2.92 mm test ports cables. 2.92 mm (K connector) calibration kit with fixed loads only. The Agilent 85056KE02 calibration kit is an ordering convenience to allow the pass through ordering from Agilent Technologies, Inc. for the Maury 8770D47 calibration kit.

The 85056KE01 and 85056KE02 contains one NMD 2.4 mm² (f) to 2.92 mm (f) and one NMD 2.4 mm² (f) to 2.92 mm (m) test port adapter to adapt the 2.4 mm test ports of the PNA to 2.92 mm. It also supplies 2.92 mm to 2.92 mm in-series adapters (3 adapters) and a PNA Cal Coefficients on a USB stick. Users must supply their own 2.92 mm or K-connector test port cables. Also included is a 2.92 mm torque wrench.

Maury Microwave Terms and Conditions for Warranty and Return apply. Maury Microwave Corp. calibration kits are to be returned directly to Maury Microwave for service, repair, or calibration issues and not to Agilent Technologies. For additional information go to www.maurymicrowave.com.

Agilent Technologies does not guarantee the performance of the Maury calibration kits or the system performance when connected to Agilent Microwave PNA Series network analyzers.

Electronic calibration kits

- **N4692A** Microwave ECal: 10 MHz to 40 GHz, 2-ports.
Includes:
 - Option M0F** module with:
 - N4692-60001 2.92 mm (f) to 2.92 mm (m) ECal module
 - Option 00M** module with:
 - N4692-60002 2.92 mm (m) to 2.92 mm (m) ECal module
 - Option 00F** module with:
 - N4692-60003 2.92 mm (f) to 2.92 mm (f) ECal module
 - Option 00A** adds:
 - N4692-60021 2.92 mm (m) to 2.92 mm (m) adapter
 - N4692-60022 2.92 mm (f) to 2.92 mm (f) adapter

Cables

Note: Agilent offers the following 2.4 mm test port cables. Adapters will be necessary when using these cables for 2.92 mm measurements.

- 85133C¹** single, semi-rigid: 2.4 mm (f) to PSC-2.4 mm (f),
81 cm, 32 inches
- 85133D¹** set, semi-rigid:
 - One 2.4 mm (f) to 2.4 mm (m), 53 cm, 21 inches,
p/n 85133-60001
 - One 2.4 mm (f) to 2.4 mm (f), 53 cm, 21 inches,
p/n 85133-60002
- 85133E¹** single, flexible: 2.4 mm (f) to PSC-2.4 mm (f),
97 cm, 38 inches
- 85133F¹** set, flexible:
 - One 2.4 mm (f) to 2.4 mm (f), 63 cm, 25 inches,
p/n 85133-60016
 - One 2.4 mm (f) to 2.4 mm (m), 63 cm, 25 inches,
p/n 85133-60017
- 85133H¹** Single, flexible: 2.4 mm (f) to 2.4 mm (m),
63 cm, 25 inches
- N4421AK20** Single, flexible: 2.4 mm (f) to 2.4 mm (m),
91.4 cm, 36 inches

Adapters

- 11904A** 2.4 mm (m) to 2.92 mm (m)
- 11904B** 2.4 mm (f) to 2.92 mm (f)
- 11904C** 2.4 mm (m) to 2.92 mm (f)
- 11904D** 2.4 mm (f) to 2.92 mm (m)
- 11904S** 2.4 mm to 2.92 mm

Adapter set, contains 4 matched adapters

1. Special rugged female connector specifically for connecting to the network analyzer test port, but does not mate with a standard male connector.

For devices with 3.5 mm or SMA connectors

Mechanical calibration kits

- **85052B** standard: DC to 26.5 GHz.

Includes:

- 00902-60003 3.5 mm (m) fixed load
- 00902-60004 3.5 mm (f) fixed load
- 00911-60019 3.5 mm (m) sliding load
- 00911-60020 3.5 mm (f) sliding load
- 85052-60006 3.5 mm (m) short
- 85052-60007 3.5 mm (f) short
- 85052-60008 3.5 mm (m) open
- 85052-60009 3.5 mm (f) open
- 85052-60012 3.5 mm (f) to 3.5 mm (f) adapter
- 85052-60013 3.5 mm (f) to 3.5 mm (m) adapter
- 85052-60014 3.5 mm (m) to 3.5 mm (m) adapter

- **85052C** precision TRL: DC to 26.5 GHz.

Includes:

- 00902-60003 3.5 mm (m) fixed load
- 00902-60004 3.5 mm (f) fixed load
- 85052-60006 3.5 mm (m) short
- 85052-60007 3.5 mm (f) short
- 85052-60008 3.5 mm (m) open
- 85052-60009 3.5 mm (f) open
- 85052-60032 3.5 mm (f) to 3.5 mm (f) adapter
- 85052-60033 3.5 mm (m) to 3.5 mm (m) adapter
- 85052-60034 3.5 mm (f) to 3.5 mm (m) adapter
- 85052-60035 3.5 mm short TRL line
- 85052-60036 3.5 mm long TRL line

- **85052D** economy: DC to 26.5 GHz.

Includes:

- 00902-60003 3.5 mm (m) fixed load
- 00902-60004 3.5 mm (f) fixed load
- 85052-60006 3.5 mm (m) short
- 85052-60007 3.5 mm (f) short
- 85052-60008 3.5 mm (m) open
- 85052-60009 3.5 mm (f) open
- 85052-60012 3.5 mm (f) to 3.5 mm (f) adapter
- 85052-60013 3.5 mm (f) to 3.5 mm (m) adapter
- 85052-60014 3.5 mm (m) to 3.5 mm (m) adapter

Electronic calibration kits

- **85093C** RF ECal: 300 kHz to 9 GHz, 2-ports

Standard module includes

Option M0F with:

- 85093-60008 3.5 mm (f) to 3.5 mm (m) ECal module

Option 00F module with:

- 85093-60010 3.5 mm (f) to 3.5 mm (f) ECal module

Option 00M module with:

- 85093-60009 3.5 mm (m) to 3.5 mm (m) ECal module

Option 00A adds:

- 85052-60012 3.5 mm (f) to 3.5 mm (f) adapter
- 85052-60014 3.5 mm (m) to 3.5 mm (m) adapter

85093C-xxx mixed-connector options:

Port A option			Port B option					
Type	(f)	(m)	Type	(f)	(m)	Type	(f)	(m)
3.5 mm	101	102	Type-N 50 ohm	203	204	7-16	205	206

- **N4431B** Microwave ECal: 300 kHz to 13.5 GHz, 4-ports.

Includes:

Option 010 module with:

- N4431-60006 4 x 3.5 mm (f) ECal module

N4431B-xxx mixed-connector options:

Connector type	Port A option	Port B option	Port C option	Port D option
3.5 mm (f)	101	201	301	401
3.5 mm (m)	102	202	302	402
Type-N 50 ohm (f)	103	203	303	403
Type-N 50 ohm (m)	104	204	304	404
7-16 (f)	105	205	305	405
7-16 (m)	106	206	306	406

- **N4433A** Microwave ECal: 300 kHz to 20 GHz, 4-ports.

Includes:

- **Option 010** module with:

- N4433-60003 4 x 3.5 mm (f) ECal module

N4433A-xxx mixed-connector options:

Connector type	Port A option	Port B option	Port C option	Port D option
3.5 mm (f)	101	201	301	401
3.5 mm (m)	102	202	302	402

- **N4691B** Microwave ECal: 300 kHz to 26.5 GHz, 2-ports.

Includes:

Option M0F module with:

- N4691-60004 3.5 mm (f) to 3.5 mm (m) ECal module

Option 00M module with:

- N4691-60005 3.5 mm (m) to 3.5 mm (m) ECal module

Option 00F module with:

- N4691-60006 3.5 mm (f) to 3.5 mm (f) ECal module

Option 00A adds:

- 85052-60012 3.5 mm (f) to 3.5 mm (f) adapter
- 85052-60014 3.5 mm (m) to 3.5 mm (m) adapter

Cables

- **85131C¹** single, semi-rigid: 3.5 mm (f) to PSC-3.5 mm (f), 81 cm, 32 inches²
- **85131D¹** set, semi-rigid:
 - One 3.5 mm (f) to 3.5 mm (m), 53 cm, 21 inches, p/n 85131-60009
 - One 3.5 mm (f) to PSC-3.5 mm (f), 53 cm, 21 inches, p/n 85131-60010
- **85131E¹** single, flexible: 3.5 mm (f) to PSC-3.5 mm (f), 96.5 cm, 38 inches²
- **85131F¹** set, flexible:
 - One 3.5 mm (f) to 3.5 mm (m), 62.2 cm, 24.5 inches, p/n 85131-60012
 - One 3.5 mm (f) to PSC-3.5 mm (f), 62.2 cm, 24.5 inches, p/n 85131-60013

1. Special rugged female connector specifically for connecting to the network analyzer test port, but does not mate with a standard male connector.

2. For use with E8362C.

- 85131H¹** single, flexible: 3.5 mm (f) to 3.5 mm (m), 62.2 cm, 24.5 inches
- 85134E¹** single, flexible: PSC-3.5 mm (f) to 2.4 mm (f), 96 cm, 38 inches
- 85134F¹** set, flexible:
 - One 2.4 mm (f) to PSC-3.5 mm (f), 53 cm, 21 inches, p/n 85134-60004
 - One 2.4 mm (f) to PSC-3.5 mm (m), 53 cm, 21 inches, p/n 85134-60003
- 85134H¹** single, flexible: 2.4 mm (f) to PSC-3.5 mm (m), 53 cm, 21 inches
- N4419AK20** single, flexible: 3.5 mm (m) to 3.5 mm (f), 91.4 cm, 36 inches
- Z5623A-K20** single, flexible: 3.5 mm (m) to 3.5 mm (m), 91.4 cm, 36 inches

Adapter sets

- 85130D** 3.5 mm¹ to 3.5 mm

For devices with Type-N connectors

Mechanical calibration kits

- 85054B** standard: DC to 18 GHz.
 - Includes:
 - 00909-60011 Type-N (m) fixed lowband load
 - 00909-60012 Type-N (f) fixed lowband load
 - 85054-60025 Type-N (m) short
 - 85054-60026 Type-N (f) short
 - 85054-60027 Type-N (m) open
 - 85054-60028 Type-N (f) open
 - 85054-60031 Type-N (f) to 7mm adapter
 - 85054-60032 Type-N (m) to 7mm adapter
 - 85054-60037 Type-N (f) to Type-N (f) adapter
 - 85054-60038 Type-N (m) to Type-N (m) adapter
 - 85054-80010 Type-N (f) sliding load
 - 85054-80009 Type-N (m) sliding load
 - 85054-60050 Type-N (f) connector gage
 - 85054-60052 Type-N (f) gage master
 - 85054-60051 Type-N (m) connector gage
 - 85054-60053 Type-N (m) gage master
- 85054D** economy: DC to 18 GHz.
 - Includes:
 - 85054-60025 Type-N (m) short
 - 85054-60026 Type-N (f) short
 - 85054-60027 Type-N (m) open
 - 85054-60028 Type-N (f) open
 - 85054-60031 Type-N (f) to 7mm adapter
 - 85054-60032 Type-N (m) to 7mm adapter
 - 85054-60037 Type-N (f) to Type-N (f) adapter
 - 85054-60038 Type-N (m) to Type-N (m) adapter
 - 85054-60046 Type-N (m) fixed load
 - 85054-60047 Type-N (f) fixed load

Adapter sets

- 85130C** 3.5 mm² to Type-N

Electronic calibration kits

- N4431B** Microwave ECal: 300 kHz to 13.5 GHz, 4-ports.
 - Includes:
 - Option 020** module with:
 - N4431-60007 4 x Type-N (f) ECal module

N4431B-xxx mixed-connector options:

Connector type	Port A option	Port B option	Port C option	Port D option
3.5 mm (f)	101	201	301	401
3.5 mm (m)	102	202	302	402
Type-N 50 ohm (f)	103	203	303	403
Type-N 50 ohm (m)	104	204	304	404
7-16 (f) ¹	105	205	305	405
7-16 (m) ¹	106	206	306	406

- N4432A** Microwave ECal: 300 kHz to 18 GHz, 4-ports.
 - Includes:
 - Option 020** module with:
 - N4432-60003 4 x Type-N (f) ECal module

N4432A-xxx mixed-connector options:

Connector type	Port A option	Port B option	Port C option	Port D option
3.5 mm (f)	101	201	301	401
3.5 mm (m)	102	202	302	402
Type-N 50 ohm (f)	103	203	303	403
Type-N 50 ohm (m)	104	204	304	404

- N4690B** Microwave ECal: 300 kHz to 18 GHz, 2-ports.
 - Includes:
 - Option M0F** module with:
 - N4690-60004 Type-N (f) to Type-N (m) ECal module
 - Option 00M** module with:
 - N4690-60005 Type-N (m) to Type-N (m) ECal module
 - Option 00F** module with:
 - N4690-60006 Type-N (f) to Type-N (f) ECal module
 - Option 00A** adds:
 - 85054-60037 Type-N (f) to Type-N (f) adapter
 - 85054-60038 Type-N (m) to Type-N (m) adapter

Cables²

Use the test port cables recommended for devices with 7 mm connectors, and 7 mm to Type-N adapters that are from the 85054B/D Type-N calibration kit (see 7 mm connector section).

1. Special rugged female connector specifically for connecting to the network analyzer test port, but does not mate with a standard male connector.
 2. For use with E8362C.

For devices with 7 mm connectors

Mechanical calibration kits

- 85050B** standard: DC to 18 GHz.
Includes:
 - 00909-60008 7 mm coax termination
 - 85050-60006 7 mm fixed broadband load
 - 85050-80007 7 mm short
 - 85050-80010 7 mm open
 - 85050-80011 7 mm sliding load
- 85050C** precision TRL: DC to 18 GHz.
Includes:
 - 00909-60008 7 mm coax termination
 - 85050-60003 7 mm to 7 mm airline
 - 85050-60005 7 mm to 7 mm TRL adapter
 - 85050-60006 7 mm fixed broadband load
 - 85050-80008 7 mm short
 - 85050-80009 7 mm short collet
 - 85050-80010 7 mm open
- 85050D** economy: DC to 18 GHz.
Includes:
 - 85050-60006 7 mm fixed broadband load
 - 85050-80007 7 mm short
 - 85050-80010 7 mm open

Electronic calibration kits

- N4696B** Microwave ECal: 300 kHz to 18 GHz, 2-ports, 7mm to 7mm Microwave module

Cables¹

- 85132E** single, flexible: 3.5 mm (f) to 7 mm, 97.2 cm, 38.25 inches²
- 85132F** set, flexible: two 3.5 mm (f) to 7 mm cables, 62.9 cm each, 24.75 inches each², p/n 85132-60004
- 85135E** single, flexible: 2.4 mm (f) to 7 mm, 96 cm, 38 inches
- 85135F** set, flexible: two 2.4 mm (f) to 7 mm cables, 53 cm each, 21 inches each, p/n 85135-60002

Adapter sets

- 85130E** 2.4 mm¹ to 7 mm

For devices with waveguide

Mechanical calibration kits

X Band

- X11644A** standard, WR-90: 8.2 to 12.4 GHz. Includes:
 - 00896-60008 X-band standard section
 - 00910-60003 X-band termination
 - 11644-20018 X-band short
 - 11644-20021 X-band shim
- 85132F** cable set (set, flexible 3.5 mm (f) to 7 mm, 62.9 cm each, 24.75 inches each²)
- 85135F** cable set (set, flexible, 2.4 mm (f) to 7 mm, 53 cm each, 21 inches each)
- X281C** adapter (included in calibration kit): WR-90 to 7 mm

P Band

- P11644A** standard, WR-62: 12.4 to 18 GHz.
Includes:
 - 00896-60007 P-band standard section
 - 00910-60002 P-band termination
 - 11644-20017 P-band short
 - 11644-20020 P-band shim
- 85132F** cable set (set, flexible, 3.5 mm (f) to 7 mm, 62.9 cm each, 24.75 inches each²)
- 85135F** cable set (set, flexible, 2.4 mm (f) to 7 mm, 53 cm each, 21 inches each)
- P281C** adapter (included in calibration kit): WR-62 to 7 mm

K Band

- K11644A** standard, WR-42: 18 to 26.5 GHz.
Includes:
 - 00896-60006 K-band standard section
 - 00910-60001 K-band termination
 - 11644-20016 K-band short
 - 11644-20019 K-band shim
- 85134F** cable set (set, flexible, 2.4 mm (f) to 3.5 mm (f) and (m), 53 cm each, 21 inches each)
- K281C** adapter (included in calibration kit): WR-42 to 3.5 mm (f)
Option 012 WR-42 to 3.5 mm (m)

R Band

- R11644A** standard, WR-28: 26.5 to 40 GHz.
Includes:
 - 00914-20028 R-band termination
 - 11644-20005 R-band short
 - 11644-20003 R-band shim
 - 11644-60001 R-band 10 cm straight waveguide
 - 11644-60016 R-band 5 cm straight waveguide
- 85133F** cable set (set, flexible, 2.4 mm, 53 cm each, 21 inches each)
- R281A** adapter (2.4 mm (f) to WR-28 waveguide adapter)
- R281B** adapter (2.4 mm (m) to WR-28 waveguide adapter)

1. For use with E8362C.

2. Special rugged female connector specifically for connecting to the network analyzer test port, but does not mate with a standard male connector.

Q Band

- Q11644A** standard, WR-22: 33 to 50 GHz.
Includes:
 - 11644-60005 Q-band termination
 - 11644-20004 Q-band short
 - 11644-20001 Q-band shim
- 11644-60002 Q-band 10 cm straight waveguide
- 11644-60017 Q-band 5 cm straight waveguide
- 85133F** cable set (set, flexible, 2.4 mm, 53 cm each, 21 inches each)
- Q281A** adapter (2.4 mm (f) to WR-22 waveguide adapter)
- Q281B** adapter (2.4 mm (m) to WR-22 waveguide adapter)

U Band

- U11644A** standard, WR-19: 40 to 60 GHz.
Includes:
 - 11644-60006 U-band termination
 - 11644-20004 U-band short
 - 11644-20002 U-band shim
 - 11644-60003 U-band 10 cm straight waveguide
 - 11644-60018 U-band 5 cm straight waveguide

V Band

- V11644A** standard, WR-15: 50 to 75 GHz.
Includes:
 - 11644-60025 V-band termination
 - 11644-20015 V/W-band short
 - 11644-20013 V-band shim
 - 11644-60012 V-band standard section

W Band

- W11644A** standard, WR-10: 75 to 110 GHz.
Includes:
 - 11643-60026 W-band termination
 - 11644-20015 V/W-band short
 - 11644-20014 W-band shim
 - 11644-60013 W-band standard section

Verification kits

All Agilent verification kits include:

- precision Z_0 airline or match thru
 - mismatched airline or mismatch thru
 - fixed attenuators
 - traceable measured data and uncertainties
- 85051B** 45 MHz to 18 GHz 7 mm kit
Includes attenuators, airline and mismatch airline with data on a 3.5-inch disk for use in confirming accuracy enhanced system measurement performance, traceable to national standards. Test procedure is provided in the service manual.
 - 85053B** 300 kHz to 26.5 GHz 3.5 mm kit
Includes attenuators, airline and mismatch airline with data on a 3.5-inch disk for use in confirming accuracy enhanced system measurement performance, traceable to national standards. Test procedure is provided in the service manual.
 - 85055A** 300 kHz to 18 GHz Type-N kit
Includes attenuators, airline and mismatch airline with data on a 3.5-inch disk for use in confirming accuracy enhanced system measurement performance, traceable to national standards. Test procedure is provided in the service manual.
 - 85057B** 45 MHz to 50 GHz 2.4 mm kit
Includes attenuators, airline and mismatch airline with data on a 3.5-inch disk for use in confirming accuracy enhanced system measurement performance, traceable to national standards. Test procedure is provided in the service manual.
 - 85058V** 45 MHz to 67 GHz 1.85 mm kit
Includes attenuators, match thru and mismatch thru with data on a 3.5-inch disk for use in confirming accuracy enhanced system measurement performance, traceable to national standards. Test procedure is provided in the service manual.

General Accessories

Spare drive¹

- N8981A** spare solid-state drive with mounting cradle
For E836xA/B and N5230A.
 - N8982A** spare solid-state drive with mounting cradle
For E836xC and N5230C.
 - N5242-60044** spare solid-state drive with mounting cradle
For N524xA with 2.0 GHz Core 2 Duo CPU.
 - N5242-60088** spare solid-state drive with mounting cradle
For N522xA/4xA with 2.0 GHz Core i7 CPU.
 - N5235-60060** spare solid-state drive with mounting cradle
For N523xA with 1.87 GHz Celeron CPU.
- Spare solid-state drive for N5242A/1A with 1.6 GHz Pentium M CPU is discontinued. Upgrading to 2.0 GHz Core i7 CPU (W1312-60196) is recommended.

Probe

- 85024A** high-frequency probe
Provides high-impedance in-circuit test capability from 300 kHz to 3 GHz.

Power meters and sensors²

Recommended for self support, adjustments and performance tests to verify proper instrument operation.

- N1913A** EPM power meter (single channel)
- N1914A** EPM power meter (dual channel)
- N8481A** power sensor, 10 MHz to 18 GHz, -35 to +20 dBm
- N8481B** power sensor, 10 MHz to 18 GHz, -5 to +44 dBm
- N8481H** power sensor, 10 MHz to 18 GHz, -15 to +35 dBm
- N8482A** power sensor, 100 kHz to 6 GHz, -35 to +20 dBm
- N8482B** power sensor, 100 kHz to 6 GHz, -5 to +44 dBm
- N8482H** power sensor, 100 kHz to 6 GHz, -15 to +35 dBm
- N8485A** power sensor, 50 MHz to 26.5 GHz, -35 to +20 dBm
- N8485A-033** average power, 10 MHz to 33 GHz, -35 to +20 dBm, 3.5 mm (m)
- N8486AQ** waveguide, 33 to 50 GHz, -35 to +20 dBm
- N8486AR** waveguide, 26.5 to 40 GHz, -35 to +20 dBm
- N8487A** power sensor, 50 MHz to 50 GHz, -35 to +20 dBm
- N8488A** power sensor, 10 MHz to 67 GHz, -35 to +20 dBm
- V8486A** waveguide power sensor, 50 to 75 GHz, -30 to +20 dBm
- W8486A** waveguide power sensor, 75 to 110 GHz, -30 to +20 dBm
- U2000A** USB sensor, 10 MHz to 18 GHz, -60 to +20 dBm
- U2000B** USB sensor, 10 MHz to 18 GHz, -30 to +44 dBm
- U2000H** USB sensor, 10 MHz to 18 GHz, -50 to +30 dBm
- U2001A** USB sensor, 10 MHz to 6 GHz, -60 to +20 dBm
- U2001B** USB sensor, 10 MHz to 6 GHz, -30 to +44 dBm
- U2001H** USB sensor, 10 MHz to 6 GHz, -50 to +30 dBm
- U2002A** USB sensor, 50 MHz to 24 GHz, -60 to +20 dBm
- U2002A-H26** USB sensor, 10 MHz to 26.5 GHz, -60 to +20 dBm
- U2002H** USB sensor, 50 MHz to 24 GHz, -50 to +30 dBm
- U2004A** USB sensor, 9 kHz to 6 GHz, -60 to +20 dBm
- E4412A** CW power sensor, 10 MHz to 18 GHz, -70 to +20 dBm
- E4413A** CW power sensor, 50 MHz to 26.5 GHz, -70 to +20 dBm
- E4413A-H33** specified performance for 50 MHz to 33 GHz

Comb generators

Two are required for NVNA. Also requires separate power supply.

- U9391C** 10 MHz to 26.5 GHz comb generator
- U9391F** 10 MHz to 50 GHz comb generator
- U9391G** 10 MHz to 67 GHz comb generator

Amplifiers

- 83006A** power amplifier, 10 MHz to 26.5 GHz, 20 dB gain, power out: +18 dBm to 10 GHz or +16 dBm to 20 GHz or +14 dBm to 26.5 GHz
- 83017A** power amplifier, 50 MHz to 26.5 GHz, 25 dB gain, power out: +20 dBm to 20 GHz, or +15 dBm to 26.5 GHz
- 83018A** power amplifier, 2 to 26.5 GHz, 27 dB gain to 20 GHz or 23 dB to 26.5 GHz, power out: +24 dBm to 20 GHz or +21 dBm to 26.5 GHz
- 83020A** power amplifier, 2 to 26.5 GHz, 30 dB gain to 20 GHz or 27 dB to 26.5 GHz, power out: +30 dBm to 20 GHz or +26 dBm to 26.5 GHz
- 83050A** power amplifier, 2 to 50 GHz, 23 dB gain, power out: +20 dBm to 40 GHz or +17 dBm to 50 GHz
- 83051A** power amplifier, 45 MHz to 50 GHz, 23 dB gain power out: +12 dBm to 45 GHz or +10 dBm to 50 GHz

Couplers

- 87300B** coaxial coupler, 1 to 20 GHz, SMA (f), 10 dB coupling
- 87300C** coaxial coupler, 1 to 26.5 GHz, 3.5 mm (f), 10 dB coupling
- 87301B** coaxial coupler, 10 to 46 GHz, 2.92 mm (f), 10 dB coupling
- 87301D** coaxial coupler, 1 to 40 GHz, 2.4 mm (f) or optional 2.92 mm (f), 13 dB coupling
- 87301E** coaxial coupler, 2 to 50 GHz, 2.4 mm (f), 10 dB coupling
- 87310B** 90° coaxial coupler, 1 to 18 GHz, SMA (f), 3 dB coupling

Equipment rack accessories

- E3663AC** Rail kit (included with Option 1CM and 1CP)
- ICM042A** Rack mount kit, for use without handles (included with Option 1CM)
- 5063-9224** Rack mount kit with handles³
- 5063-9230** Front handle kit³
- 5063-9237** Rack mount kit, for use with classic handles (included with Option 1CP)³

Monitors

VGA-compatible monitor

Interface cables

Choose the appropriate cables to connect each peripheral to the network analyzer.

- 10833A** GPIB cable, 1.0 m (3.3 ft)
- 10833B** GPIB cable, 2.0 m (6.6 ft)
- 10833D** GPIB cable, 0.5 m (1.6 ft)
- 82357B** GPIB to USB interface

1. For more information on solid-state drive, refer to na.tm.agilent.com/pna/hdnumbers.html

2. For the latest guide to power meters and power sensors, refer to the Agilent web site: www.agilent.com/find/powermeters

3. 5063-9224 is a complete rack mount kit with handles. N52xxA comes with ruggedized handles, which must be replaced with classic handles shipped with the kit. 5063-9230 is a pair of classic handles, and used with 5063-9237 for mounting N52xxA to a rack.

www.agilent.com
www.agilent.com/find/pna



myAgilent

www.agilent.com/find/myagilent

A personalized view into the information most relevant to you.



www.axistandard.org

AdvancedTCA[®] Extensions for Instrumentation and Test (AXIe) is an open standard that extends the AdvancedTCA for general purpose and semiconductor test. Agilent is a founding member of the AXIe consortium.



www.lxistandard.org

LAN eXtensions for Instruments puts the power of Ethernet and the Web inside your test systems. Agilent is a founding member of the LXI consortium.



www.pxisa.org

PCI eXtensions for Instrumentation (PXI) modular instrumentation delivers a rugged, PC-based high-performance measurement and automation system.

Agilent Channel Partners

www.agilent.com/find/channelpartners

Get the best of both worlds: Agilent's measurement expertise and product breadth, combined with channel partner convenience.



Three-Year Warranty

www.agilent.com/find/ThreeYearWarranty

Agilent's combination of product reliability and three-year warranty coverage is another way we help you achieve your business goals: increased confidence in uptime, reduced cost of ownership and greater convenience.



Agilent Advantage Services

www.agilent.com/find/AdvantageServices

Accurate measurements throughout the life of your instruments.



www.agilent.com/quality

For more information on Agilent Technologies' products, applications or services, please contact your local Agilent office. The complete list is available at:

www.agilent.com/find/contactus

Americas

Canada	(877) 894 4414
Brazil	(11) 4197 3600
Mexico	01800 5064 800
United States	(800) 829 4444

Asia Pacific

Australia	1 800 629 485
China	800 810 0189
Hong Kong	800 938 693
India	1 800 112 929
Japan	0120 (421) 345
Korea	080 769 0800
Malaysia	1 800 888 848
Singapore	1 800 375 8100
Taiwan	0800 047 866
Other AP Countries	(65) 375 8100

Europe & Middle East

Belgium	32 (0) 2 404 93 40
Denmark	45 45 80 12 15
Finland	358 (0) 10 855 2100
France	0825 010 700*
	*0.125 €/minute
Germany	49 (0) 7031 464 6333
Ireland	1890 924 204
Israel	972-3-9288-504/544
Italy	39 02 92 60 8484
Netherlands	31 (0) 20 547 2111
Spain	34 (91) 631 3300
Sweden	0200-88 22 55
United Kingdom	44 (0) 118 927 6201

For other unlisted countries:

www.agilent.com/find/contactus

Revised: October 11, 2012

Product specifications and descriptions in this document subject to change without notice.

© Agilent Technologies, Inc. 2012, 2013
Published in USA, March 27, 2013
5990-7745EN

Pentium[®] is a U.S. registered trademark of Intel Corporation.



Agilent Technologies