



Agilent PNA and PNA-L Series Microwave Network Analyzers

The standard in microwave network analysis



Anticipate — Accelerate — Achieve



Agilent Technologies

PNA Family Sets the Standard for Microwave Network Analysis

Choose the leader

The PNA family builds on Agilent's 45-year legacy of excellence in network analysis to deliver new standards in performance, speed, accuracy, and versatility for microwave component test. The PNA family includes:

PNA-X Series - Agilent's most advanced and flexible network analyzer, providing complete linear and nonlinear component characterization in a single instrument with a single set of connections

PNA Series - the industry's highest performing network analyzer, offering many advanced measurement applications

PNA-L Series - designed for S-parameter and simple nonlinear testing of passive components, amplifiers, and frequency converters

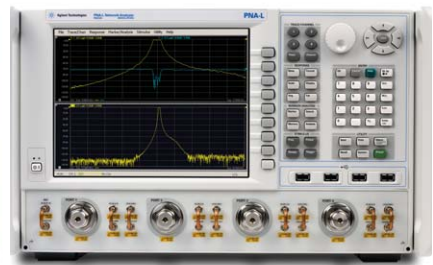
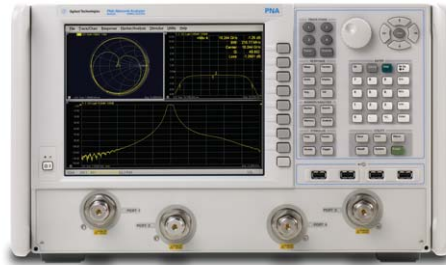
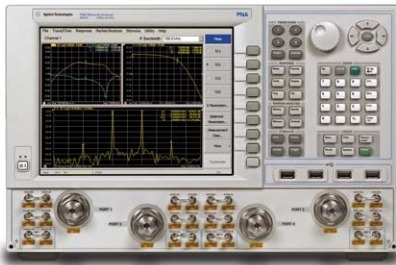

PNA-X Series Network Analyzers

- N5241A 10 MHz to 13.5 GHz
- N5242A 10 MHz to 26.5 GHz
- N5244A 10 MHz to 43.5 GHz
- N5245A 10 MHz to 50 GHz
- N5247A 10 MHz to 67 GHz

PNA Series Network Analyzers

- N5221A 10 MHz to 13.5 GHz
- N5222A 10 MHz to 26.5 GHz
- N5224A 10 MHz to 43.5 GHz
- N5225A 10 MHz to 50 GHz
- N5227A 10 MHz to 67 GHz

PNA-L Series Network Analyzers

- N5239A 300 kHz to 8.5 GHz
- N5231A 300 kHz to 13.5 GHz
- N5232A 300 kHz to 20 GHz
- N5234A 10 MHz to 43.5 GHz
- N5235A 10 MHz to 50 GHz

2 ports 300 kHz to 8.5 GHz

2, 4 ports 10 MHz to 13.5 GHz

2, 4 ports 10 MHz to 13.5 GHz

2, 4 ports 300 kHz to 13.5 GHz

2, 4 ports 300 kHz to 20 GHz

2, 4 ports 10 MHz to 26.5 GHz

2, 4 ports 10 MHz to 26.5 GHz

2, 4 ports 10 MHz to 43.5 GHz

2, 4 ports 10 MHz to 43.5 GHz

2 ports 10 MHz to 43.5 GHz

2, 4 ports 10 MHz to 50 GHz

2, 4 ports 10 MHz to 50 GHz

2 ports 10 MHz to 50 GHz

2, 4 ports 10 MHz to 67 GHz

2, 4 ports 10 MHz to 67 GHz

2, 4 ports 10 MHz to 1.05 THz

2, 4 ports 10 MHz to 1.05 THz

PNA-X

PNA

PNA-L

Complete Solutions for a Wide Range of Applications

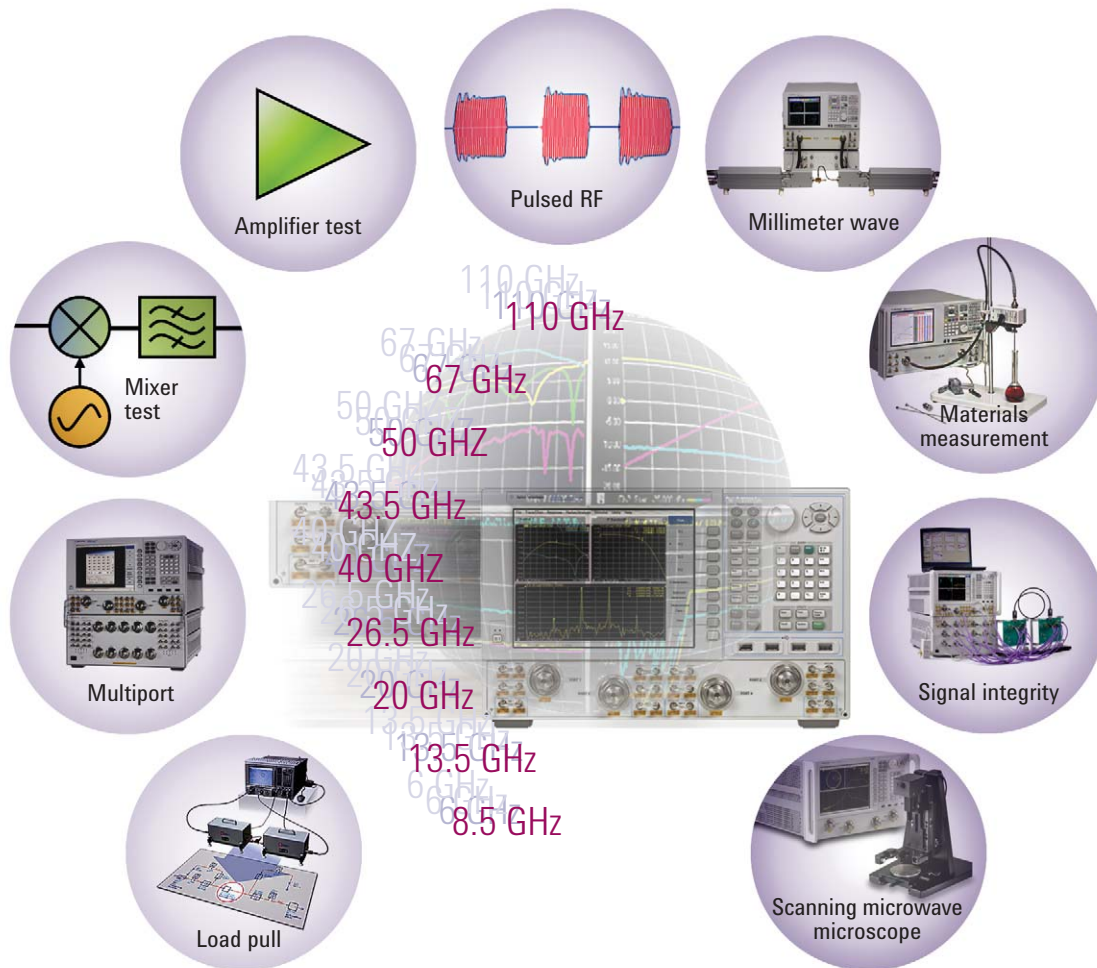

In addition to being very capable standalone network analyzers, PNA and PNA-L instruments often form the core of more advanced measurement systems to serve a variety of microwave measurement applications.

Future-proof your microwave component testing

All members of the PNA family share a common software platform that makes it easy to choose just the right level of performance to match your budget and measurement needs. This commonality guarantees measurement consistency and repeatability and a common remote-programming interface across multiple instruments in R&D and manufacturing. All of the powerful PNA software options can be added later to meet future test requirements.



The PNA's built-in help system provides a complete user's guide, including measurement tutorials and programming documentation.

Innovative Features Across The PNA Family

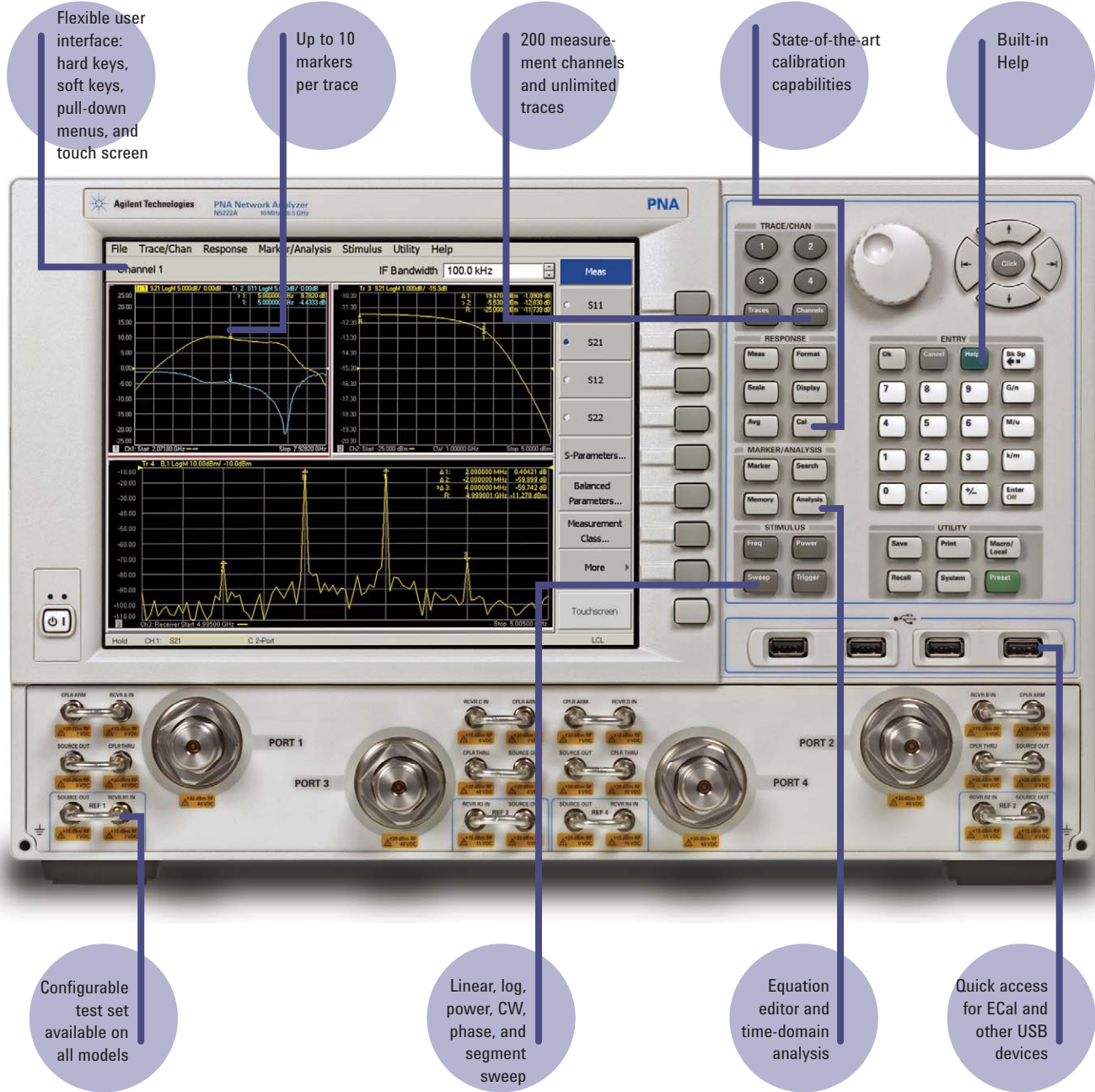

All PNA models integrate a high resolution display with a touch screen, which provides a crisp view and easy access to all data and traces. This enhanced user interface allows intuitive operation and helps you set up complex measurements quickly.

Connectivity to Match Your Application

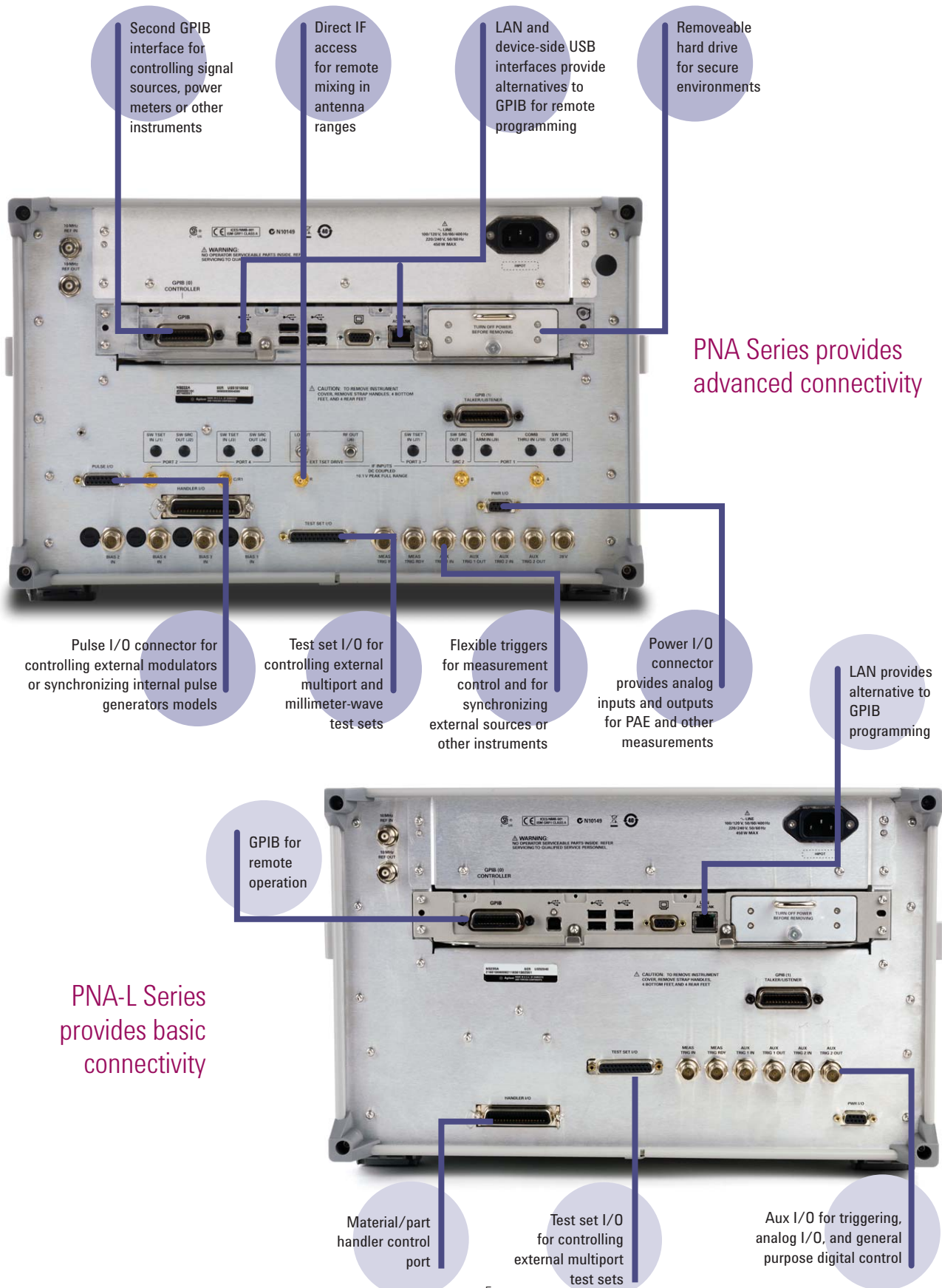

PNA Series

The PNA Series of network analyzers offers industry-leading performance for testing amplifiers, mixers and frequency converters. The PNA Series provides a winning combination of excellent hardware and powerful measurement applications to measure a broad range of devices fast and accurately. All models are available in 2-port single-source and 4-port dual-source versions. Pulsed S-parameters are easy using built-in pulse modulators and pulse generators.

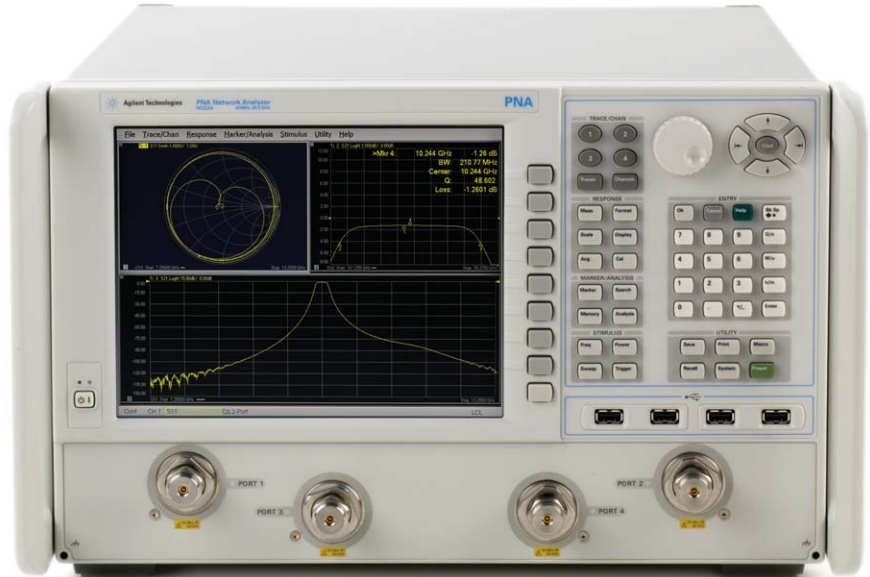

Highest performance

- High source output power of +13 dBm at 1 GHz to +11 dBm at 67 GHz
- High dynamic range: 127 dB at 20 GHz at test port
- Low trace noise: 0.002 dB rms at 1 kHz bandwidth
- Low receiver noise floor
- High receiver compression level
- Fast measurement speed: 3.6 to 23 μ sec/point
- High stability: < 0.03 dB/ $^{\circ}$ C

Advanced applications

Many of the measurement applications developed for the PNA-X are now available for the PNA, such as:

- Pulsed-RF (Option 008)
- Gain compression (Option 086)
- Intermodulation distortion (Option 087)
- Noise figure using standard receivers (Option 028)
- Source-phase control (Option 088)
- True-mode stimulus (Option 460)
- Frequency converters (Options 082, 083)
- Embedded-LO (Option 084)

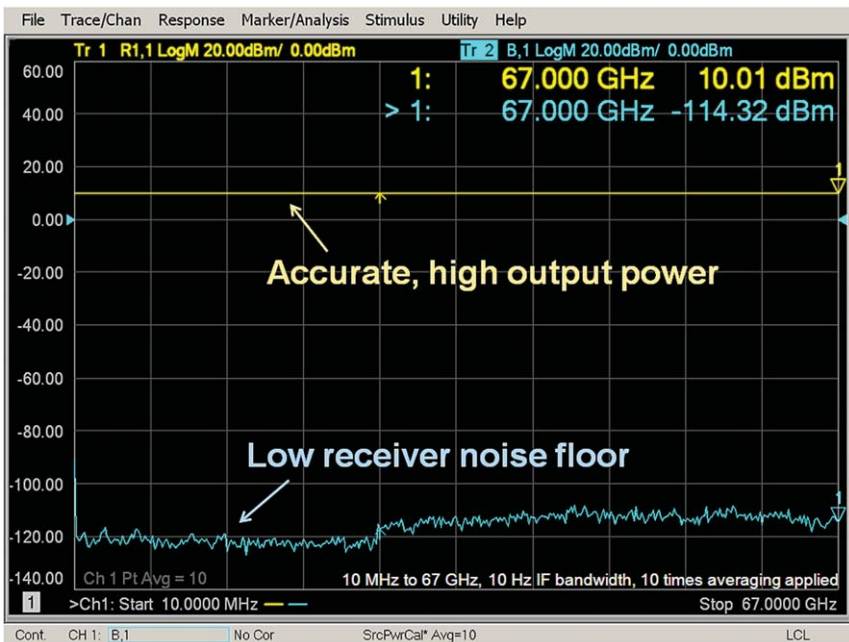

With receiver-leveled output power of +10 dBm and a receiver noise floor of -114 dBm, the PNA typically has 124 dB of dynamic range at 67 GHz, more than any other network analyzer in this frequency range.

PNA Series

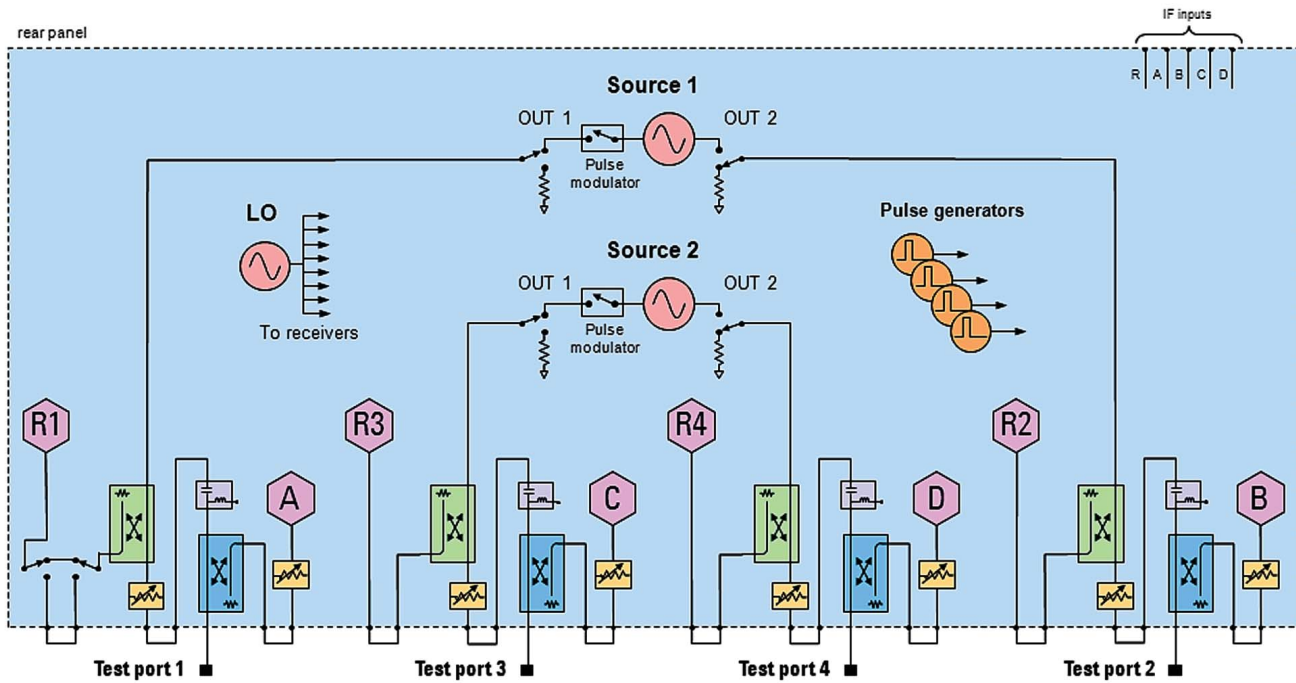

PNA Series block diagram shown with test set Option 419, plus pulse and external-IF options.

Performance	Legacy PNA E836x	New PNA N522x
Port power, 20 GHz	+3 dBm	+13 dBm
System dynamic range, 20 GHz	123 dB	127 dB
Receiver compression, 0.1 dB	-5 dBm	+12 dB
Source power sweep range	27 dB	38 dB
Minimum pulse width, wideband detection	50 us	100 ns

The new PNA Series network analyzers offer significantly better performance compared to legacy models.

Choose the Right Hardware For Your Test Needs

	Legacy PNA-L N5230C/ PNA-L N523xA	Legacy PNA E836x	PNA N522xA	PNA-X N524xA
2-ports, single source	•	•	•	•
2-ports, dual source				•
4-ports, dual source	• ¹		•	•
Low-harmonic sources (< -60 dBc)				•
Test set without front-panel RF loops	•	•	•	
Test set with front-panel RF loops	•	•	•	•
Switchable rear-panel RF loops				•
Source attenuators	•	•	•	•
Receiver attenuators		•	•	•
Bias tees		•	•	•
External IF inputs		•	•	•
RF, LO outputs for millimeter extenders		•	•	•
Internal pulse modulators			•	•
Internal pulse generators			•	•
IF gates for narrowband pulse detection		•	•	•
R1 reference receiver switch		•	•	•
Internal signal combiner				•
Noise figure using standard receivers			•	•
Noise figure using low-noise receivers				•
Nonlinear vector network analyzer options				•

1. Dual source is only available on legacy PNA-L N5230C 13.5 and 20 GHz, 4-port.

More information about the PNA-X can be found online at www.agilent.com/find/pna-x or in the **PNA-X Series brochure, 5990-4592EN**

PNA Series Innovative Applications

Simple, fast, and accurate pulsed-RF measurements (Options 008, 021, 022, 025)

Pulsed-RF measurement challenges

- Pulse generators and modulators required for pulsed-RF measurements add complexity in test setups
- For narrow pulses:
 - Maximum IF bandwidth of analyzer is often too small for wideband detection
 - Narrowband detection is slow, and measurements are noisy for low duty cycle pulses

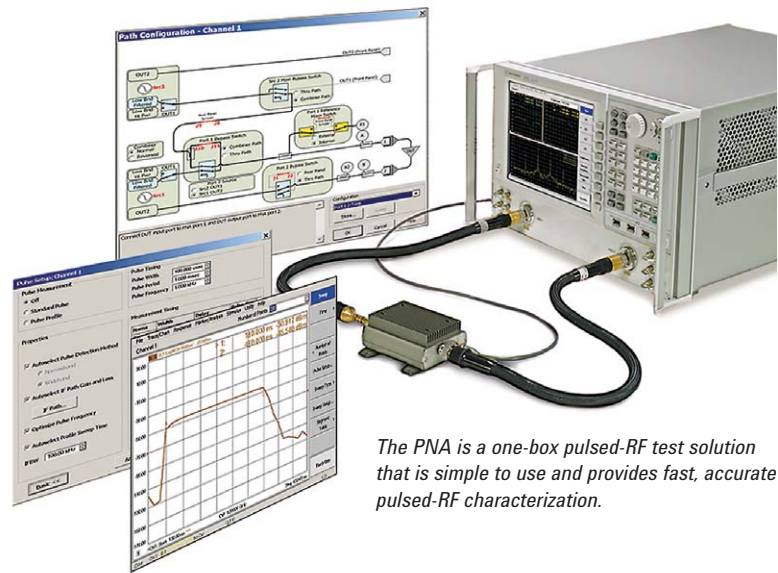

The PNA is a one-box pulsed-RF test solution that is simple to use and provides fast, accurate pulsed-RF characterization.

PNA pulsed-RF measurements provide:

- A simple user interface for full control of two internal pulse modulators (Option 021 and 022), and four internal independent pulse generators (Option 025)
- Point-in-pulse measurements with 20 ns minimum pulse width, and pulse profile measurements with 10 ns minimum resolution (Option 008)
- Improved measurement speed and accuracy for narrowband detection using hardware filters and patented spectral-nulling and software IF-gating techniques
- Measurements using wideband detection with pulse widths as narrow as 100 ns
- Receiver leveling for accurate source-power control
- Pulse I/O connector on rear panel for synchronization with external equipment and DUT
- Accurate active-component characterization using unique application measurement classes for gain compression, swept-frequency/power IMD, and noise figure

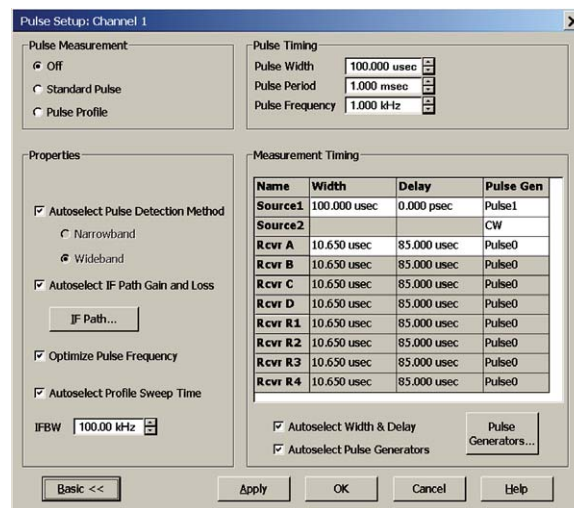

The pulsed-RF measurement application automatically optimizes the internal hardware configuration for specified pulse conditions to dramatically simplify test setups. Alternately, users can choose to manually set up the hardware for unique test requirements.

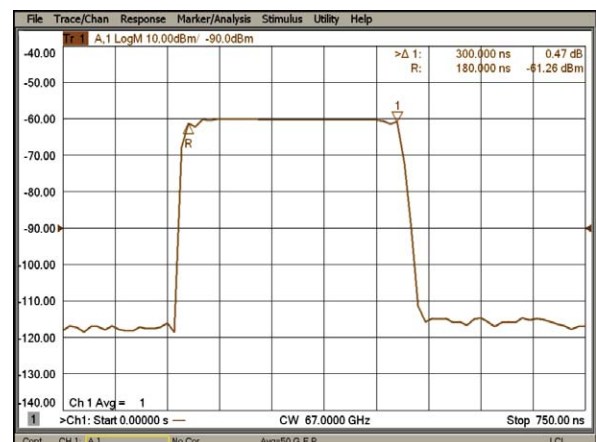

Pulse profile measurement using narrowband detection method allows 300 ns sweep time with 30 data points.

PNA Series Innovative Applications

Fast, accurate gain compression versus frequency measurements of amplifiers and converters (Option 086)

Gain compression measurement challenges

- Characterizing amplifier or frequency converter compression over its operating frequency range requires measurements at many frequency and power points, so setting up the measurements, calibration, and data manipulation takes a lot of time and effort
- A variety of errors degrade measurement accuracy, such as mismatch between the test port and the power sensor and DUT during absolute power measurements, and using linear S-parameter error correction in nonlinear compression measurements

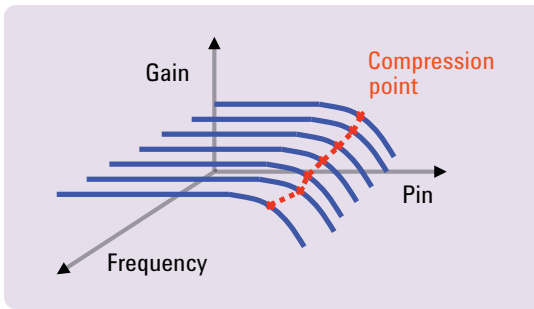

A network analyzer is commonly used for gain compression measurements by performing power sweeps at multiple CW frequencies. The PNA's GCA makes it easy to characterize compression over the DUT's operating frequency range with extreme speed and accuracy, and a simple setup.

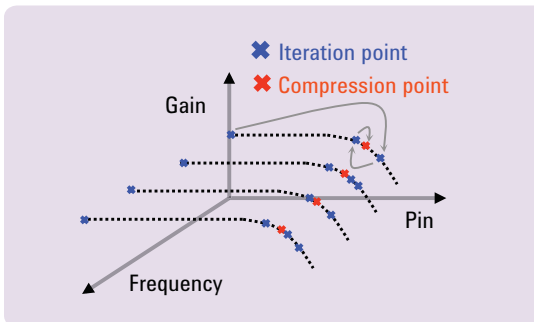

Instead of a linear power sweep with many points, GCA's SMART Sweep uses an adaptive algorithm to find the desired compression point at each frequency with just a few power measurements, thus significantly reducing test times.

PNA gain compression application (GCA) provides:

- Fast and convenient measurements with SMART Sweep, which greatly reduces the number of power points required to fully characterize compression versus frequency
- Highly accurate results using a guided calibration that provides power and mismatch correction
- Complete device characterization with two-dimensional (2D) sweeps, with the choice of sweeping power per frequency, or frequency per power
- Flexibility with a variety of compression methods — compression from linear gain, maximum gain, X/Y compression, compression from back-off, or compression from saturation

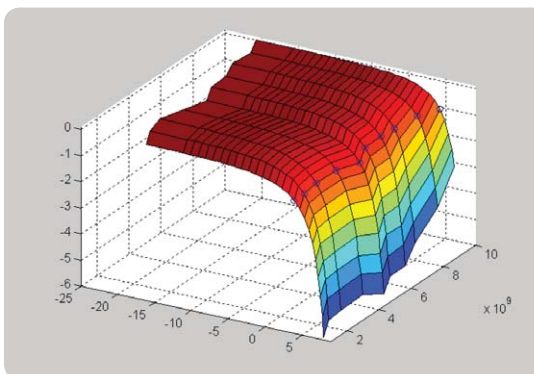
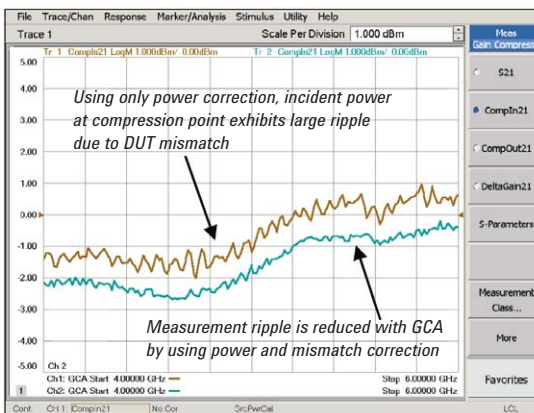

Complete device response to 2D sweeps—gain versus frequency and power—can be extracted for device modeling.

PNA Series Innovative Applications

Fast two-tone intermodulation distortion (IMD) measurements with simple setup (Option 087)

IMD measurement challenges

- Two signal generators, a spectrum analyzer, and an external combiner are most commonly used, requiring manual setup of all instruments and accessories
- Test times are slow when swept-frequency or swept-power IMD is measured
- Instruments and test setups often cause significant measurement errors due to source-generated harmonics, cross-modulation, and phase noise, plus receiver compression and noise floor

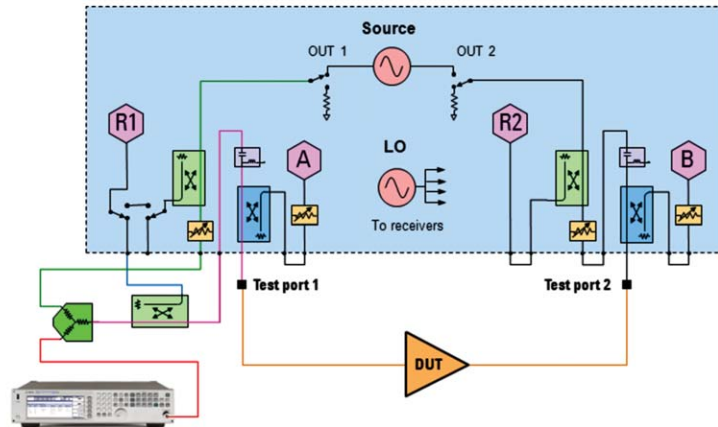

A 2-port PNA can be used with an external signal source, combiner and coupler for IMD measurements.

PNA IMD application provides:

- Fast swept-IMD measurements of amplifiers and frequency converters
- Quick and easy measurements with an intuitive user interface
- Guided calibration that simplifies the calibration procedure and provides high measurement accuracy
- Spectrum analyzer mode for troubleshooting or making spurious measurements, eliminating the need for a separate spectrum analyzer

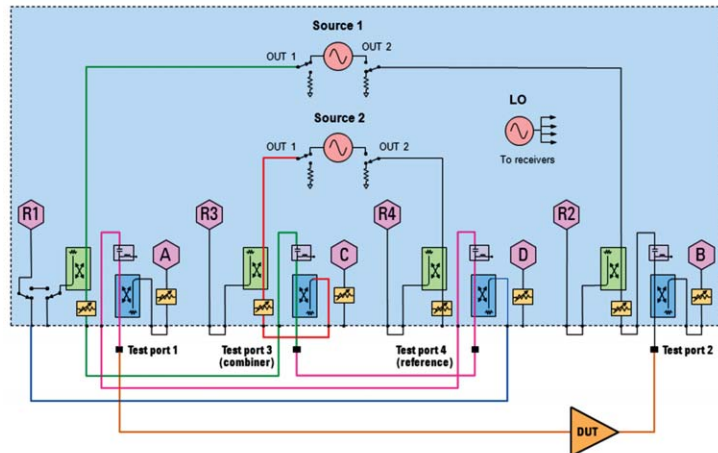

On a 4-port PNA, the two internal sources can be used to create the IMD stimulus. Unused test port couplers can be used as a combiner and reference coupler.

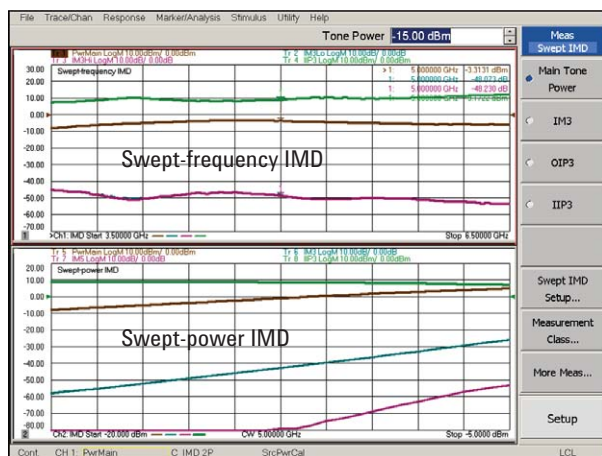

IMD application measures third order IMD and IP3 at 201 frequency (or power) points in a matter of seconds, compared to several minutes using signal generators and a spectrum analyzer.

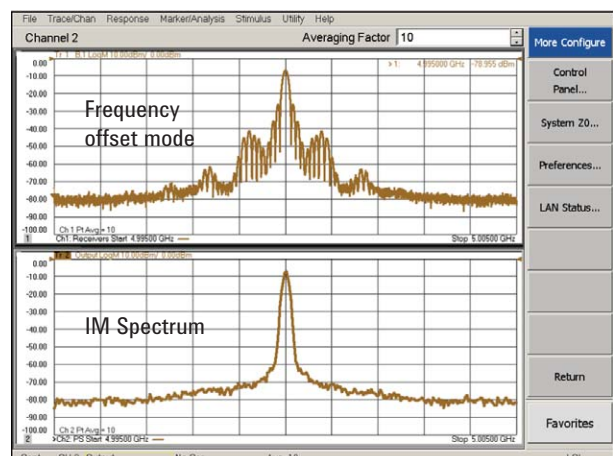

Frequency-offset mode is commonly available in VNA's, but conventional IF filter responses exhibit high side lobes. The IM Spectrum mode employs an optimized digital-IF filter along with software pre-selection, to provide true spectrum measurement capability in the PNA.

PNA Series Innovative Applications

Fast and accurate noise figure measurements (Option 028)

Noise figure measurement challenges with traditional, Y-factor approach

- Multiple instruments and multiple connections required to fully characterize DUT
- Measurement accuracy degrades in fixtured, on-wafer, and automated-test environments, where noise source cannot be connected directly to DUT
- Measurements are slow, often leading to fewer measured data points and misleading results due to under-sampling

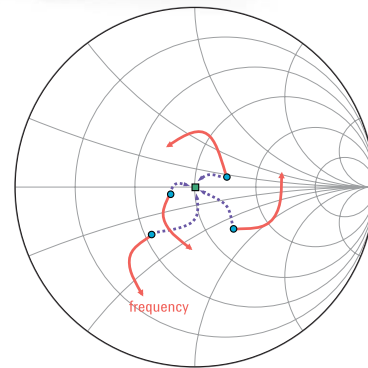

At each test frequency, four or more noise measurements are made with known, non-50-ohm source impedances. From these measurements, 50-ohm noise figure is accurately calculated.

PNA noise figure solution provides:

- Amplifier and frequency converter measurements with the highest accuracy in the industry, using advanced error-correction methods
- Correction for imperfect system source match by using vector correction to remove mismatch errors plus an ECal module used as an impedance tuner to remove noise-parameter-induced errors
- High measurement accuracy in fixtured, on-wafer, or automated-test environments
- Fast measurements: typically 4 to 10 times faster than Agilent's NFA Series noise figure analyzers
- Accurate measurements of differential devices using vector deembedding of baluns or hybrids

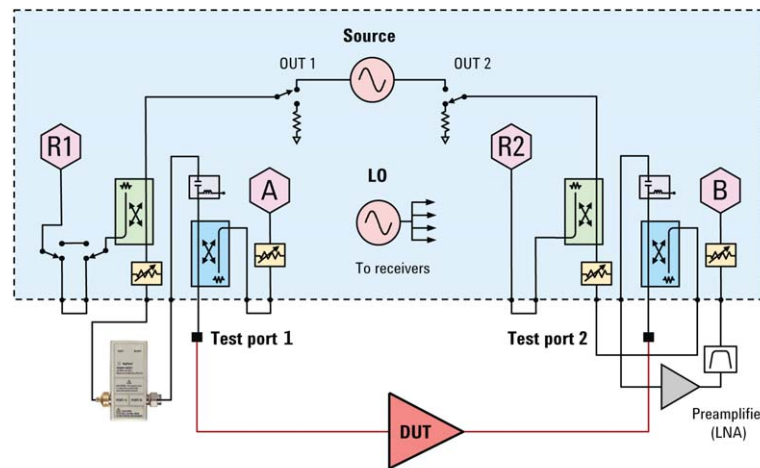

PNA noise figure measurement setup using an ECal module as an impedance tuner, and an external LNA and filter for improved sensitivity and measurement accuracy.

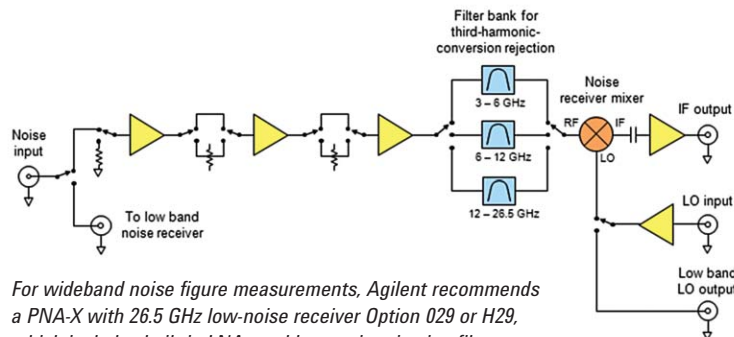

For wideband noise figure measurements, Agilent recommends a PNA-X with 26.5 GHz low-noise receiver Option 029 or H29, which includes built-in LNAs and harmonic-rejection filters.

PNA Series Innovative Applications

Fast, high-gamma active-load amplifier characterization (Option 088)

Load-characterization measurement challenges

- Handling high-power DUTs
- Mechanical tuners cannot supply fully reflective loads
- Mechanical tuners are slow

PNA source-phase control application provides:

- Fast active-loads using built-in second source or an external source
- Full reflection with user-defined fixed or swept phase angles
- Measurements of amplifier output power, match, and gain under different load conditions
- Hybrid setups that combine mechanical and active tuning for fundamental and harmonic load pull

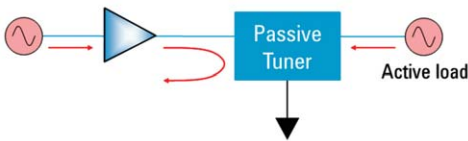

In a hybrid load-pull setup, the passive tuner provides the majority of the reflected signal, so the power required of the active load for full reflection is much lower.

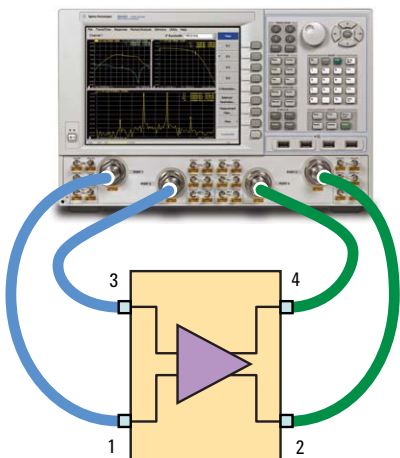

Using the PNA's two internal sources, iTMSA drives the differential amplifier under real world conditions, providing accurate mixed-mode S-parameters in all operating environments.

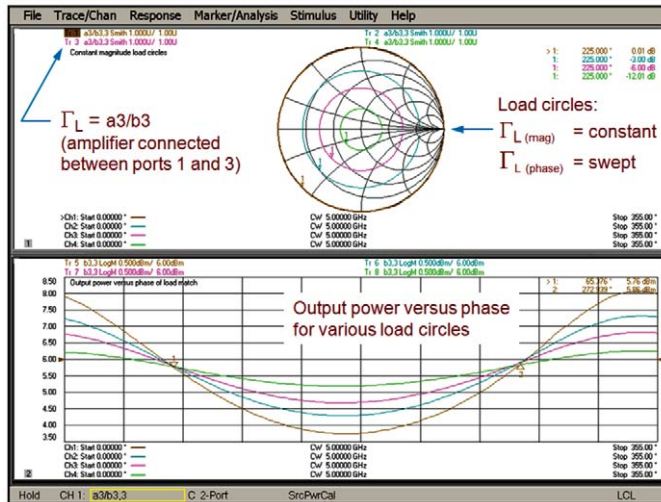

Top window shows phase sweeps generating active-load circles with constant-magnitude reflection. Bottom window shows the output power of the DUT versus load phase for various load circles.

Testing differential amplifiers under real operating conditions (Option 460)

Differential amplifier measurement challenges

- Conventional two-port VNAs with baluns do not provide common-mode and mixed-mode responses
- Baluns are inherently band-limited devices, which forces multiple test setups for broad frequency coverage
- Phase errors of baluns provide inaccurate differential responses
- Modern four-port VNAs provide mixed-mode S-parameter measurements with single-ended stimulus, but differential amplifiers may respond differently when in compression during real operating environments

PNA integrated true-mode stimulus application (iTMSA) provides:

- Mixed-mode S-parameters of differential amplifiers driven by true differential and common-mode signals
- Mismatch correction at the DUT input to minimize phase and amplitude errors between the two sources
- Input-only drive mode that prevents damage on amplifiers caused by stimulus on the output port
- In-fixture arbitrary phase offset and phase-offset sweeps to optimize input matching network for maximum amplifier gain

PNA Series Innovative Applications

Accurate characterization of mixers and converters (Options 082, 083, 084)

Mixer and converter measurement challenges

- Traditional approach with spectrum analyzer and external signal sources is cumbersome, slow, and does not provide phase or group delay information
- Conventional VNAs require an external signal source, which degrades sweep speed
- Conventional VNAs provide phase or group delay data relative to a “golden” device
- Attenuators are often used to minimize ripple due to input and output mismatch, at the expense of dynamic range and calibration stability

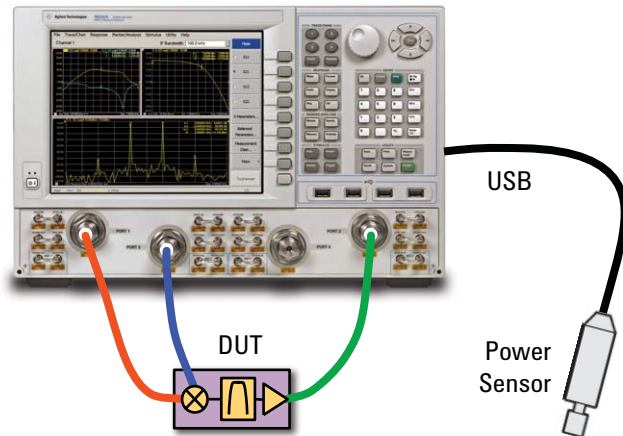

The scalar mixer/converter (SMC) setup is simple and provides input and output match, and the most accurate conversion loss/gain measurements, plus calibrated absolute delay with Option 083.

PNA frequency converter applications provide:

- Simple setup using internal second signal source as a local oscillator (LO) signal
- Typical measurement time improvement of 100x compared to spectrum analyzer-based approach
- High measurement accuracy using two patented techniques:
 - Scalar mixer/converter (SMC) provides match and most accurate conversion loss/gain measurements by combining two-port and power-meter calibrations (Option 082), and with Option 083, calibrated absolute group delay measurements without a reference mixer
 - Vector mixer/converter (VMC) provides match, conversion loss/gain, and low-noise measurements of phase and absolute group delay, using a vector-calibrated through mixer (Option 083)
- Input and output mismatch correction reduces ripple and eliminates the need for attenuators

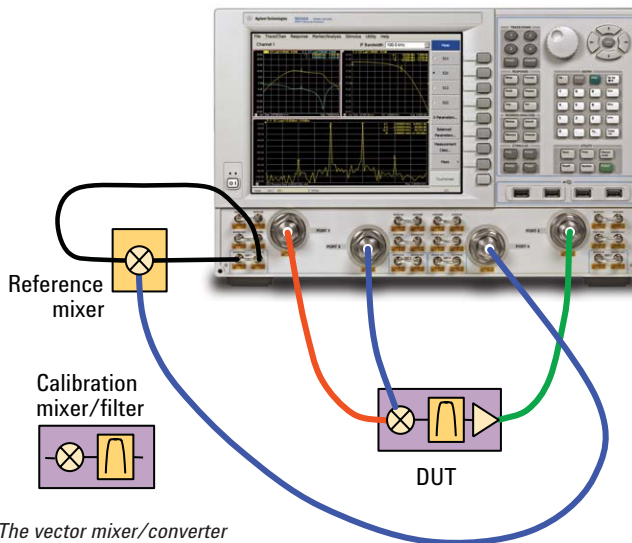

The vector mixer/converter technique provides input and output match, conversion loss/gain, and low-noise measurements of phase and absolute group delay.

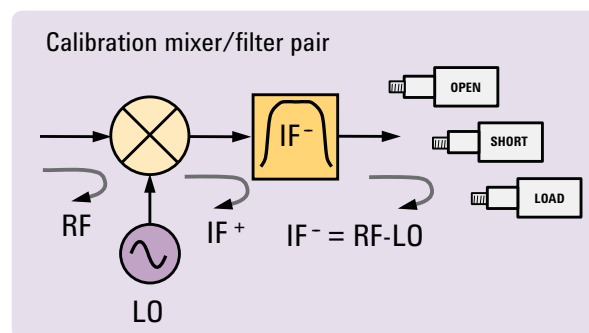

Agilent's frequency converter application vector-mixer-characterization method uses open, short, and load standards and reflection measurements to create a characterized, frequency-translating through standard.

PNA Series Innovative Applications

Measuring Converters with Embedded LOs (Option 084)

Embedded-LO Option 084

- Uses coarse- and fine-tuning sweeps to calculate LO deviation from nominal value
- Automatically tunes the PNA receivers to correct for DUT LO drift, sweep by sweep
- Works with:
 - Noise figure application, Options 028/029/H29
 - Scalar mixer/converter Application, Option 082
 - Frequency converter application, Option 083
 - Gain compression application, Option 086
 - Intermodulation distortion application, Option 087

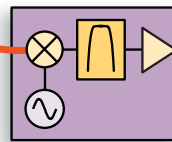
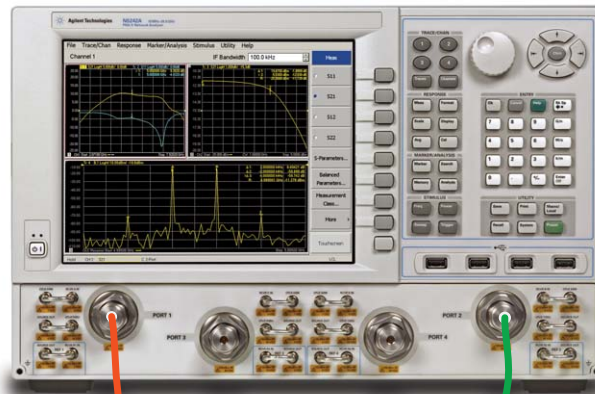

DUT

Option 084 can be used in conjunction with many other PNA-X active-measurement options to test converters with embedded LOs, without need for access to internal time bases.

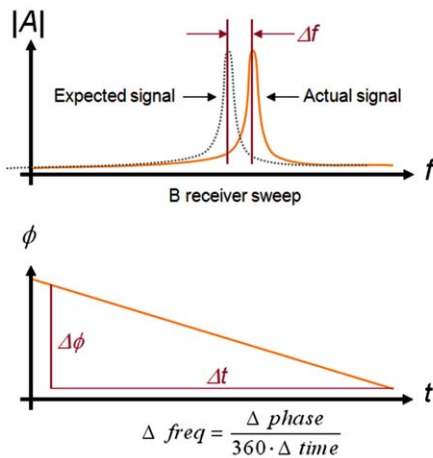

Option 084 uses a coarse frequency sweep (top) to determine the nominal LO offset. A phase-versus-time sweep (bottom) is used to fine-tune the estimate of LO offset.

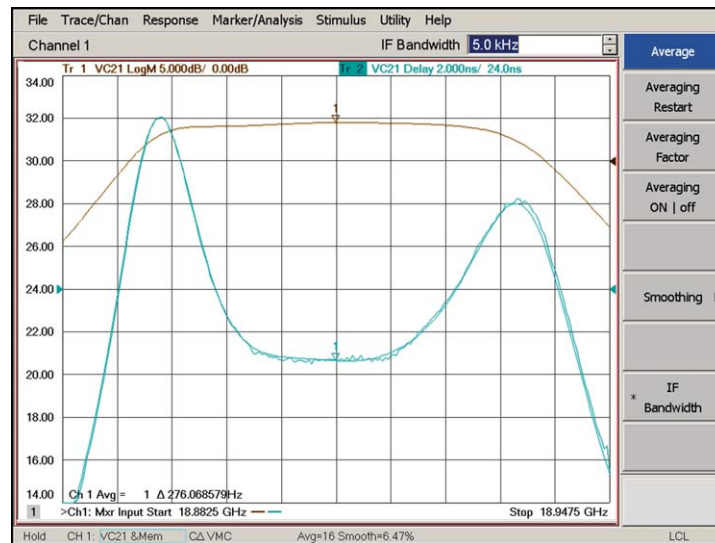

Comparing converter measurements with a locked and unlocked LO shows excellent measurement correlation. Averaging and modest amounts of smoothing are often used to increase accuracy and precision when measuring devices with embedded LOs.

PNA Series Innovative Applications

Extending the PNA to millimeter-wave frequencies

PNA's unique hardware architecture provides:

- Two- and four-port solutions for measurements on a wide variety of single-ended and balanced millimeter-wave devices
- True-mode differential measurements at millimeter-wave frequencies using two internal sources
- Fully integrated solution for millimeter-wave pulse measurements using built-in pulse modulators, pulse generators, and receiver gates
- Accurate leveled power at millimeter-wave frequencies with advanced source-power calibration methods
- Direct connection of terahertz modules driven by a 50 GHz PNA
- Single-sweep network analysis from 10 MHz to 110 GHz with full power-level control, using the 67 GHz PNA and millimeter-wave extension modules

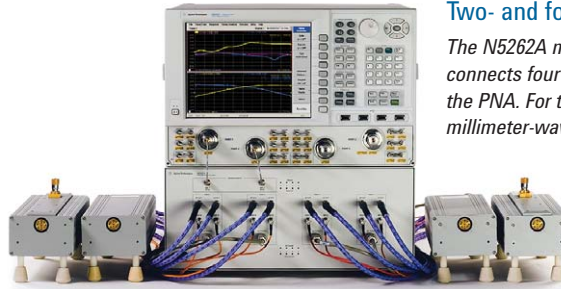

Two- and four-port banded solutions

The N5262A millimeter-wave test-set controller connects four millimeter-wave test modules to the PNA. For two-port measurements, the N5261A millimeter-wave test-set controller is available.

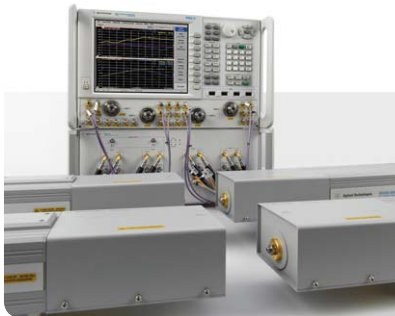

Two- and four-port broadband, single-sweep solutions (10 MHz to 110 GHz)

PNA-based 110 GHz systems come in two- and four-port versions, with power-level control, true-differential stimulus, and the ability to measure frequency converters with SMC. These systems are table-top replacements for 8510XF systems, with superior performance.



Terahertz solutions without a test set

Direct connection of VDI modules to a 50 GHz PNA enables S-parameter measurements to 1.05 THz.

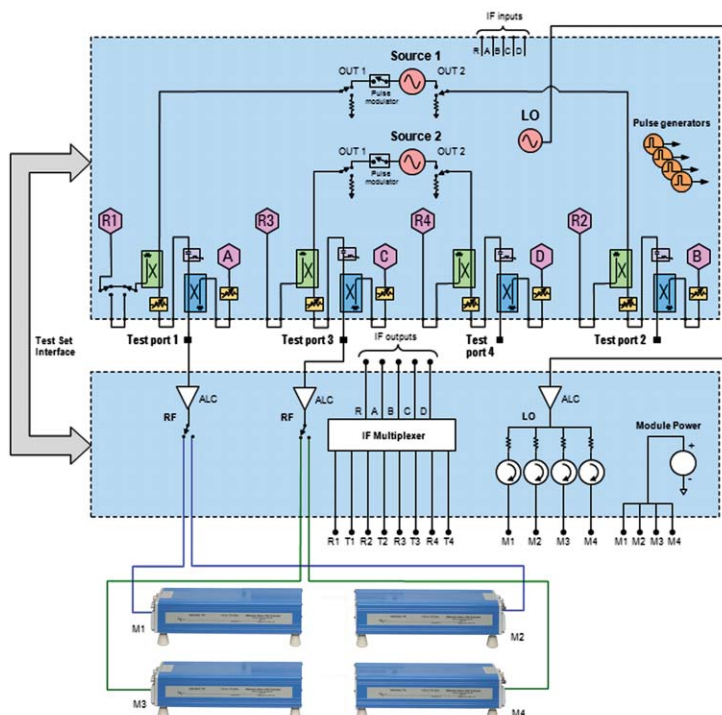

Four-port system architecture

Block diagram of a 4-port millimeter-wave system with coherent source control of OML modules using the N5262A millimeter-wave test-set controller.

PNA Series Innovative Applications

Millimeter-wave applications with the PNA

Integrated pulse measurements

The PNA's internal pulse modulators create pulsed-RF signals for the millimeter-wave modules, making it easy to set up and perform pulsed millimeter-wave measurements.

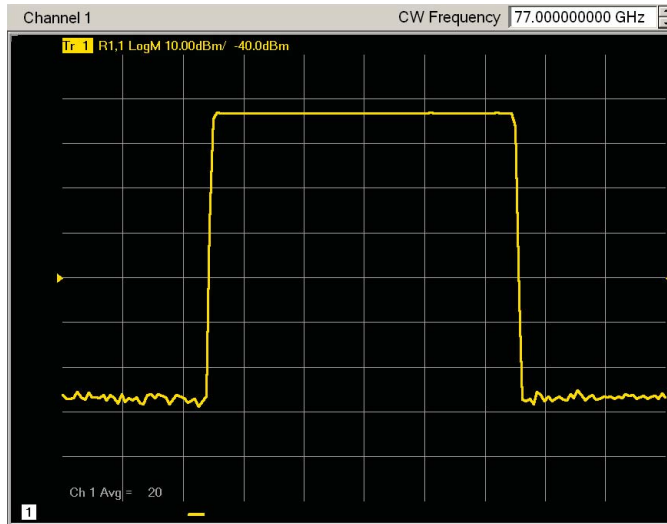

Pulse profile at 77 GHz using the internal pulsed source and IF gates of the PNA.

Scalar mixer measurements

A two-module system can be used to provide fundamental RF and LO signals to a millimeter-wave mixer for conversion loss measurements.

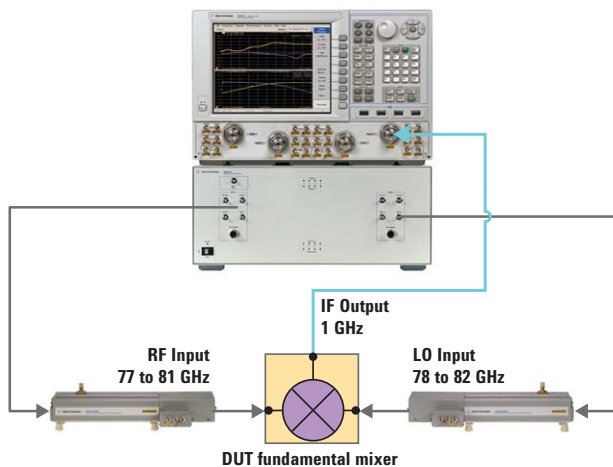

Two-module system for measuring millimeter-wave mixers and converters.

Gain compression

Using calibrated source-power sweeps, the PNA provides the most accurate millimeter-wave gain-compression measurements in the industry.

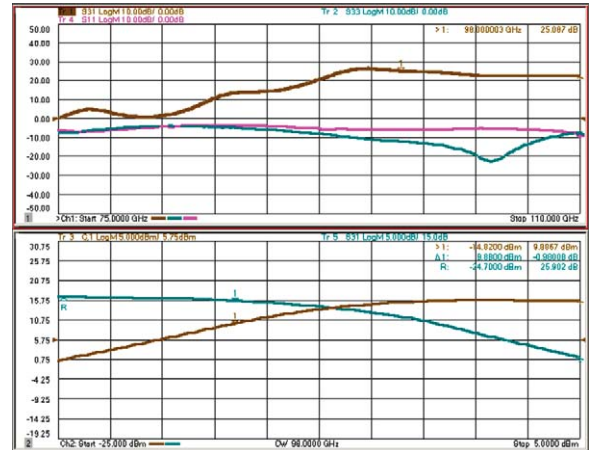

Example gain compression measurement of a 75 to 110 GHz packaged PHEMT transistor amplifier.

True-mode differential measurements at millimeter-wave frequencies

- Highest measurement accuracy in the industry using advanced error-correction methods
- Integrated phase sweeps with power control

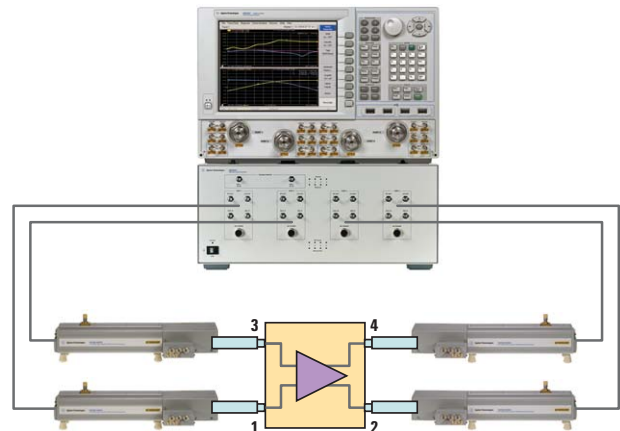

True differential measurement of a balanced LNA using a PNA-X, the N5262A millimeter-wave test-set controller, and four millimeter-wave test modules.

PNA-L: Passive and Active Device Test at Affordable Prices

The Agilent PNA-L is designed for your general-purpose network analysis needs and priced for your budget. With the same core firmware as the PNA, the PNA-L offers the perfect balance of value and performance. The PNA-L provides efficiency and flexibility in both manufacturing and R&D applications, for industries ranging from mobile-telecomm and wireless-LAN component production to aerospace and defense.

Balanced/differential components

For passive devices that have one or more balanced/differential ports, the PNA-L is an excellent choice for mixed-mode S-parameter measurements, without the need or limitations of using baluns.

- Display differential-, common-, and mixed-mode performance, in a variety of trace formats
- Measurement parameters include common-mode-rejection ratio and amplitude and phase imbalance
- Supported port configurations include single-ended-to-balanced and balanced-to-balanced topologies

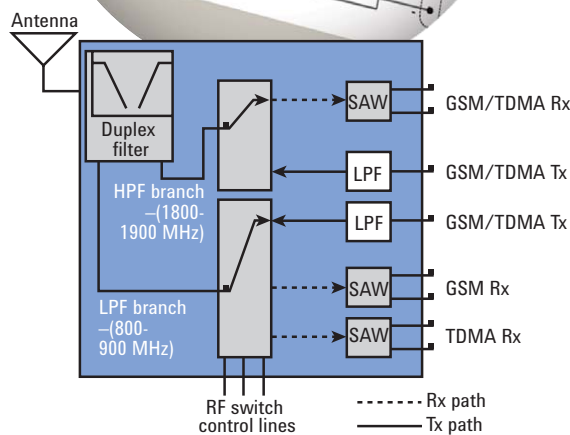
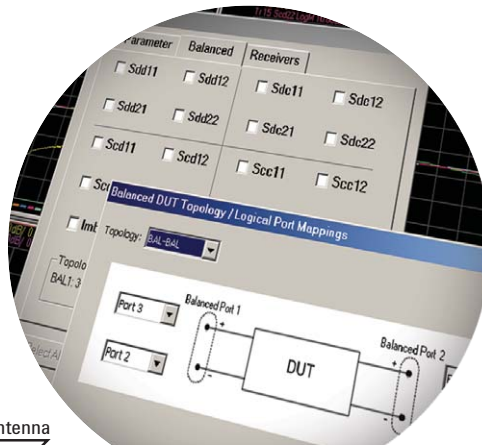
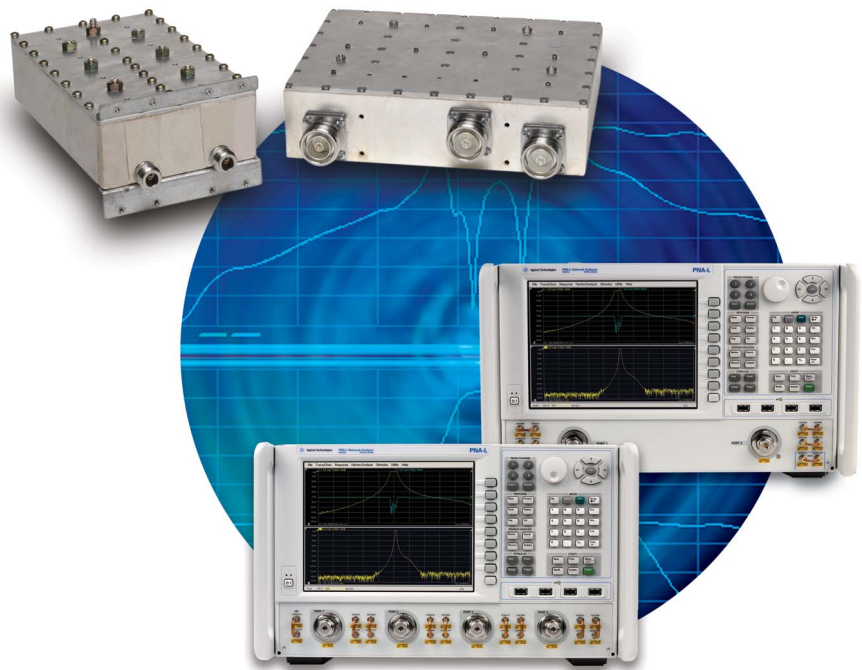

PNA-L Series Block Diagrams

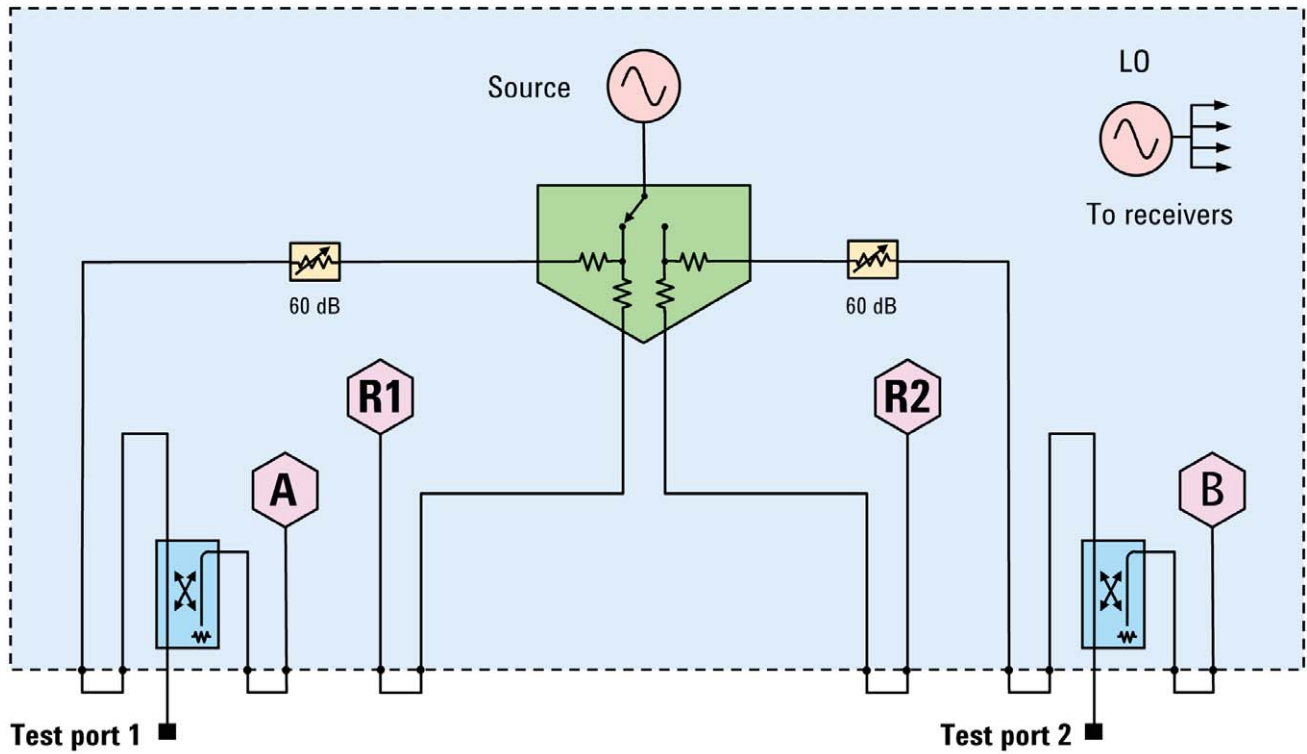

PNA-L Series 2-port block diagram shown with test set Option 216.

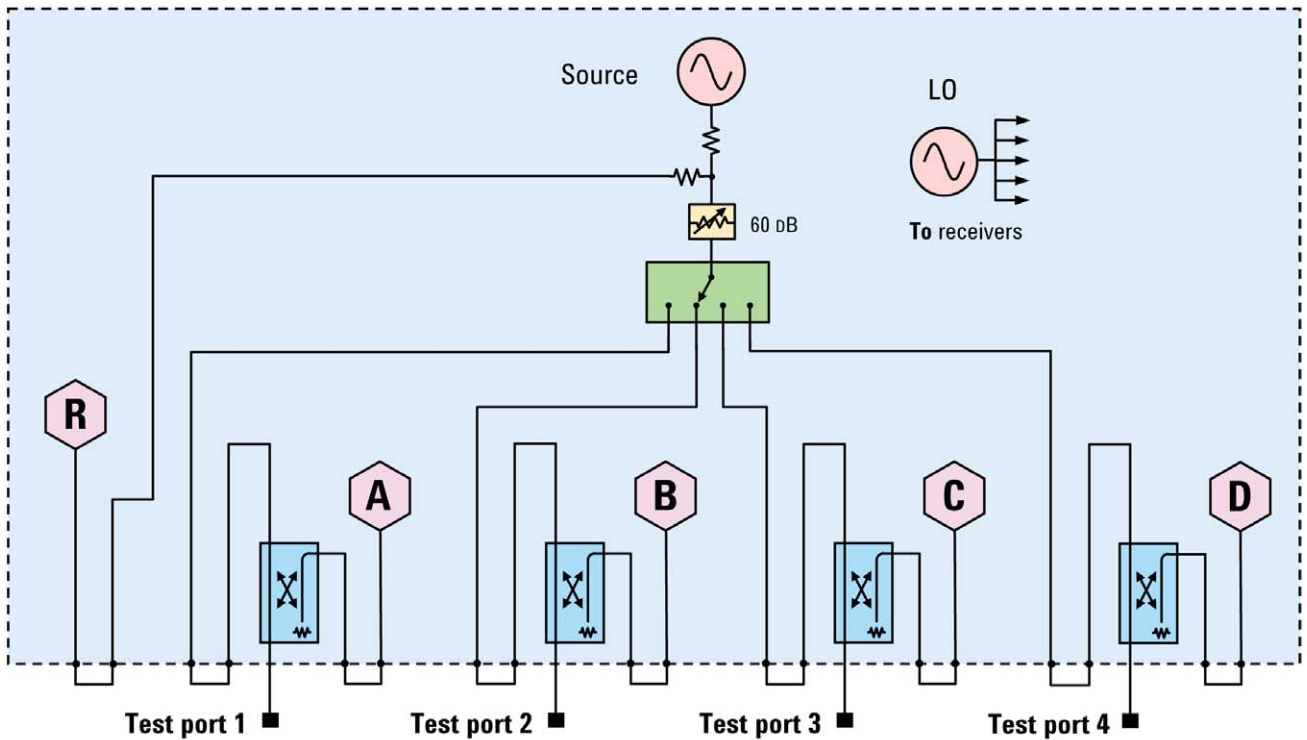

PNA-L Series 4-port block diagram shown with test set Option 416.

PNA-L Series: The Economical Choice for Signal Integrity and Material Measurements

Physical Layer Test Software (PLTS)

The Agilent PNA-L is the ideal microwave engine to power Agilent's PLTS software.

PLTS provides:

- Forward and reverse reflection and transmission measurements, with time- and frequency-domain displays targeted specifically for signal-integrity analysis
- Guided setup, calibration, and data acquisition
- Full modal analysis including single-ended, differential, and cross-mode conversions
- A powerful, virtual bit-pattern generator to create eye diagrams based on measured channel data
- Highly accurate RLCG models to enhance the accuracy of your models and simulations
- Automatic fixture removal for symmetric and asymmetric fixtures
- Advanced formula editor for user-defined equations such as power sums for crosstalk-compliance measurements

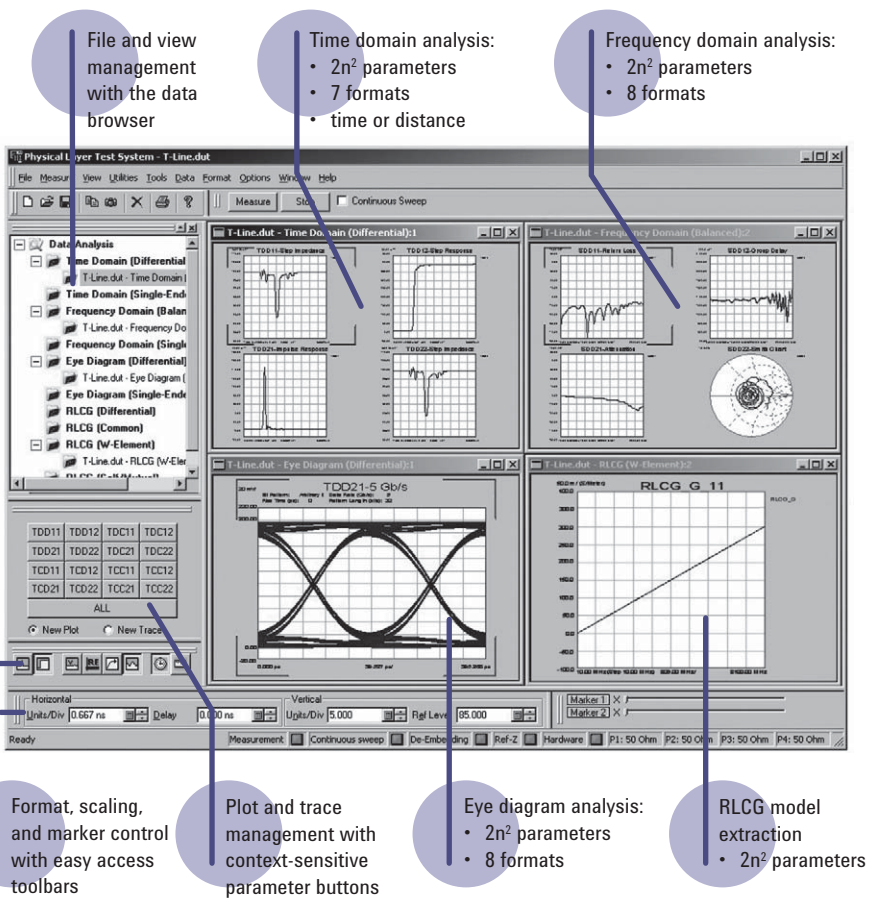

PLTS provides a wealth of analysis tools for signal-integrity engineers.

Materials measurements

Agilent offers several tools to help determine the intrinsic electromagnetic properties of materials, including 85071E materials measurement software, 85070E dielectric probe kit, and 85072A split cylinder resonator. The complete system is based on a versatile Agilent network analyzer like the PNA-L, which measures the material's response to RF or microwave energy.

Agilent material measurements solutions provide:

- Control of the network analyzer to automate complex permittivity and permeability measurements versus frequency

- Display of results in a variety of formats (ϵ_r' , ϵ_r'' , $\tan \delta$, μ_r' , μ_r'' , $\tan \delta_m$ and Cole-Cole)
- A variety of measurement methods and mathematical models to meet most application needs
- Support for many different probes and fixtures, as well as free-space measurements
- Data easily shared with other Windows®-based programs or through the component object model (COM) interface

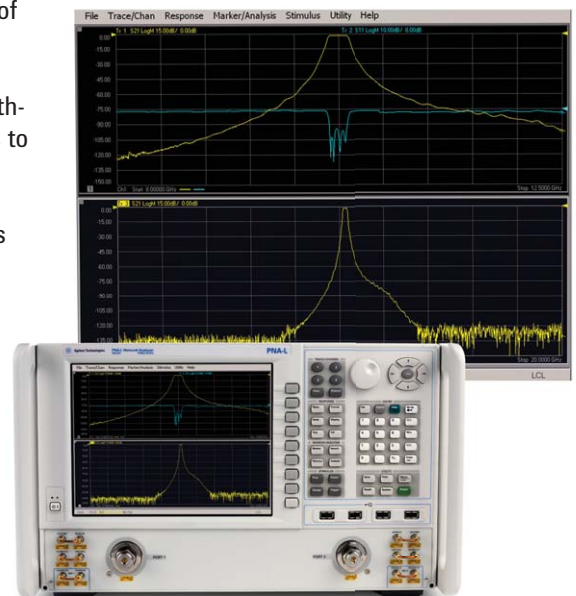

On-Wafer Measurements with the PNA Family

PNA and PNA-L network analyzers can easily be integrated with a microwave probe station to form a complete on-wafer measurement system. All of the PNA's powerful measurement applications can be used for on-wafer devices. When calibration requires a power sensor, the PNA firmware guides the user through the steps required to align power and S-parameter calibration planes into a single set of on-wafer reference planes.

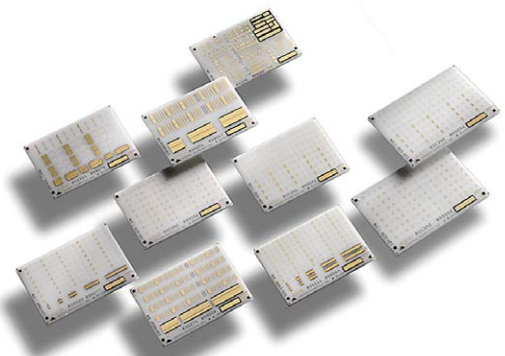
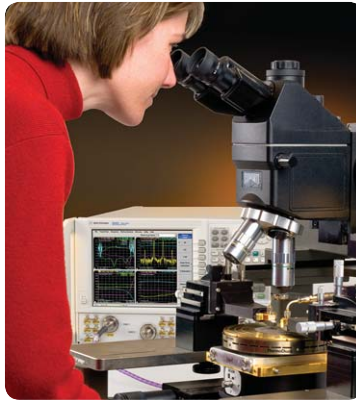

PNA-based on-wafer solutions provide:

- Measurements on filters, amplifiers, and frequency converters
- Complete set of TRL-class calibrations for accurate measurements
- Differential measurement capability using single-ended or true-mode stimulus
- Accurate power-level control for precise power measurements
- Probe-characterization macro to easily measure S-parameters of probes for deembedding

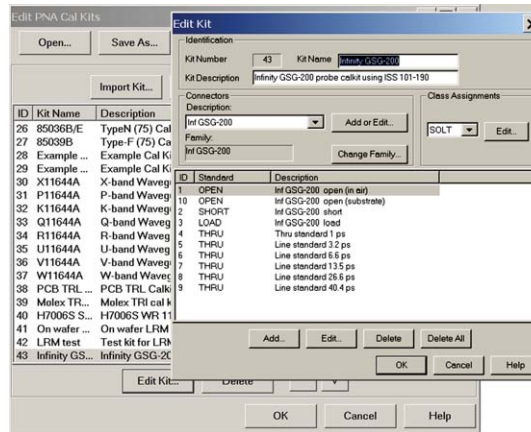

The PNA cal kit editor makes it easy to enter impedance-substrate standard (ISS) definitions for on-wafer calibration

Complete wafer-probe solutions from Cascade Microtech

Cascade Microtech is the worldwide leader for high-quality microwave probing systems and is an official Agilent Solutions Partner. Cascade offers a broad variety of test stations and probes to cover any application and frequency range. In addition, WinCal XE software enhances RF measurement accuracy and productivity through guided system setup, automatic calibration and validation, test sequencing, and other advanced RF measurement tools.

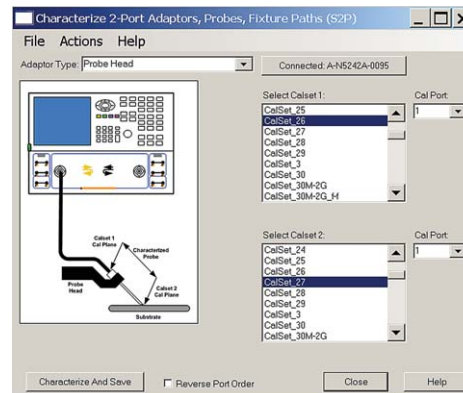

Extend the Power of the PNA Family to Multiport Devices

Multiport test challenges:

- Many components have more than 4 ports
- Moving test cables is slow and prone to errors
- Standard two-port calibration doesn't correct for ports outside the test path, resulting in degraded accuracy

PNA and PNA-L multiport solutions provide:

- Integrated test systems consisting of a network analyzer and an external multiport test set, seamlessly controlled by the PNA's firmware
- A single set of test connections to the DUT, resulting in high test throughput
- High accuracy with advanced calibration methods.
- Full compatibility with PLTS

Flexible test set hardware

- Test couplers on each port provide accurate and stable measurements
- External signal conditioning hardware such as attenuators, amplifiers, or isolators can be added as needed to handle a variety of device types
- Get full cross-bar switching to cover any DUT, or limit the test paths to match those required by a specific DUT

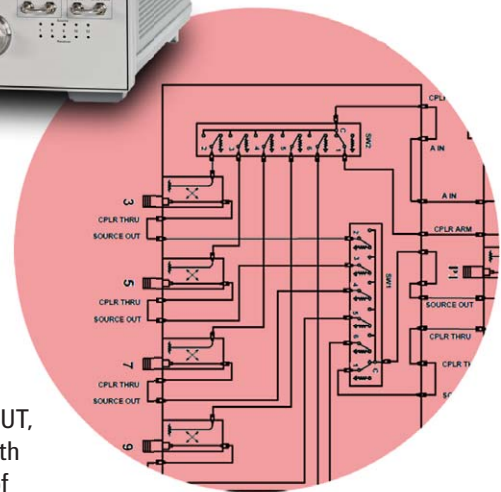

Advanced calibration

- N-port calibration corrects the load match at all ports of the DUT, whether they are in the test path or not. This gives a high level of accuracy, independent of the isolation between ports of the DUT.
- QSOLT (quick short, open, load, thru) calibration reduces the number of correction standards required for full N-port calibration
- Application-specific calibrations to support compression, IMD, and noise figure can be applied in conjunction with the test set

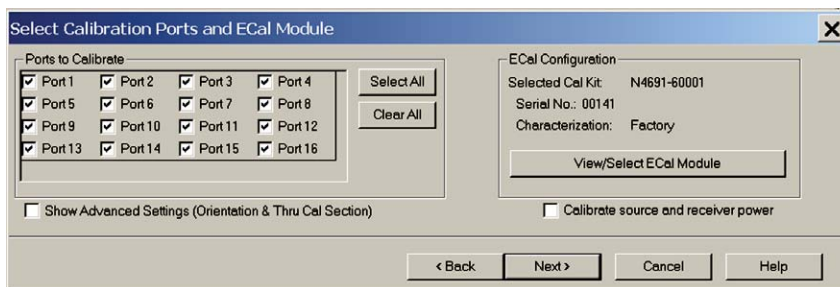

Completing The Solution

Advanced calibration tools

Calibrating network analyzers is critical for high accuracy measurements and can be particularly challenging in non-coaxial environments such as in-fixture, on-wafer, or waveguide. The PNA family supports a broad range of mechanical and electronic calibration kits, and offers advanced calibration methods to enhance ease-of-use while providing best-in-class accuracy. Agilent calibration tools include:

- High-performance two-and four-port ECal modules, covering 300 kHz to 67 GHz, with nine connector types
- QSOLT and n-port calibration for multiport test systems
- Data-based calibration-standard models and expanded math for enhanced accuracy at high frequencies
- Match-corrected power measurements to eliminate mismatch errors
- Software fixturing for deembedding, port matching, and impedance transformation



Protect your software investment

Agilent protects your 8753, 8720 and 8510 software investment by providing migration tools to reduce your code conversion effort.

www.agilent.com/find/nadisco

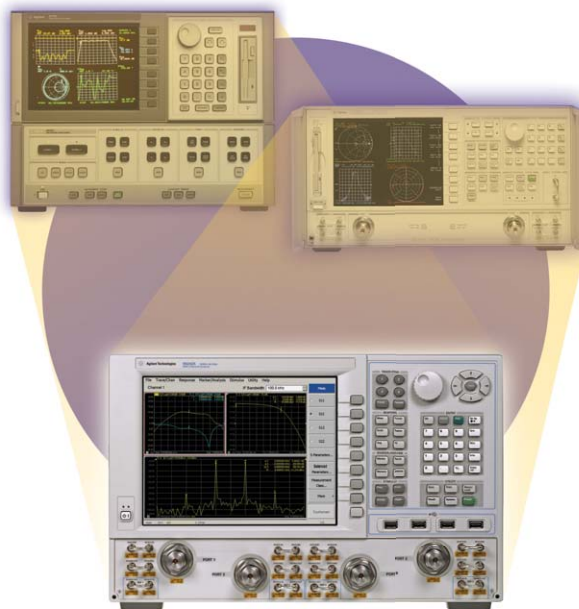

Network analyzer forum

Visit the online network analyzer discussion forum where you can learn how your peers are solving some of their most challenging measurement problems.

www.agilent.com/find/agilent_naforum

Application notes

More information about PNA network analyzer applications can be found at www.agilent.com/find/pnaapps

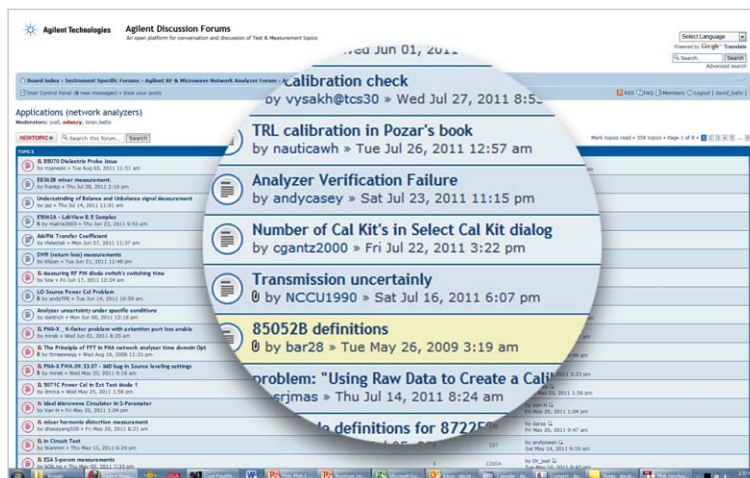

Additional resources can be found at:

www.agilent.com/find/accessories
www.agilent.com/find/antenna
www.agilent.com/find/ecal
www.agilent.com/find/materials
www.agilent.com/find/multiport
www.agilent.com/find/plts
www.agilent.com/find/pna
www.agilent.com/find/pulsedrf



Agilent Email Updates

www.agilent.com/find/emailupdates

Get the latest information on the products and applications you select.



www.lxistandard.org

LAN eXtensions for Instruments puts the power of Ethernet and the Web inside your test systems. Agilent is a founding member of the LXI consortium.

Agilent Channel Partners

www.agilent.com/find/channelpartners

Get the best of both worlds: Agilent's measurement expertise and product breadth, combined with channel partner convenience.



www.agilent.com/find/pna

www.agilent.com
www.agilent.com/find/pna

For more information on Agilent Technologies' products, applications or services, please contact your local Agilent office. The complete list is available at:

www.agilent.com/find/contactus

Americas

Canada	(877) 894 4414
Brazil	(11) 4197 3600
Mexico	01800 5064 800
United States	(800) 829 4444

Asia Pacific

Australia	1 800 629 485
China	800 810 0189
Hong Kong	800 938 693
India	1 800 112 929
Japan	0120 (421) 345
Korea	080 769 0800
Malaysia	1 800 888 848
Singapore	1 800 375 8100
Taiwan	0800 047 866
Other AP Countries	(65) 375 8100

Europe & Middle East

Belgium	32 (0) 2 404 93 40
Denmark	45 45 80 12 15
Finland	358 (0) 10 855 2100
France	0825 010 700*
	*0.125 €/minute
Germany	49 (0) 7031 464 6333
Ireland	1890 924 204
Israel	972-3-9288-504/544
Italy	39 02 92 60 8484
Netherlands	31 (0) 20 547 2111
Spain	34 (91) 631 3300
Sweden	0200-88 22 55
United Kingdom	44 (0) 118 927 6201

For other unlisted countries:

www.agilent.com/find/contactus

Revised: January 6, 2012

Product specifications and descriptions in this document subject to change without notice.

© Agilent Technologies, Inc. 2011, 2012
Published in USA, July 3, 2012
5990-8290EN

Windows and MS Windows are U.S. registered trademarks of Microsoft Corporation.



Agilent Technologies